

Handler Series Utility Carts

Stainless Steel Tough Transport® - 1000 Lb. Capacity

Models

4938, 4939, 4943**4944, 4958, 4959**

Model 4938

The Smart Ergonomic Choice For Maneuvering In Confined Spaces

- 1000 lb. (450 kg) capacity is ideal for continuous hauling of heavy loads over uneven floors and outdoor surfaces
- Shelves are 14-gauge stainless steel with reinforced edges front and back
- All joints are continuous welded
- One-piece ergonomic push handle
- Stainless steel construction resists staining and rusting
- Heavy-duty wide tread 5" swivel non-marking casters
- Easy to clean and sanitize
- NSF listed



Specifications

Unit is of fully welded stainless steel construction. Legs and frame are of U-frame design, eliminating the need for corner reinforcements. Shelves are 14-gauge stainless steel, and are continuously TIG welded to vertical leg frames. Shelves are reinforced front and back with 18-gauge angle welded to the shelf underside. Unit has four each 5" (127 mm) diameter extra-load swivel casters with 1-1/4" (32 mm) wide non-marking polyurethane wheels. One-piece tubular stainless steel ergonomic handle is shipped unassembled. Unit has two each 6" (152 mm) bumpers riveted to front legs. Casters are plate mount type, bolted to an 18-gauge 5" wide stainless steel cross member with a galvanized reinforcement. Unit is NSF listed.

Spec. #

A/A #

Lakeside Manufacturing, Inc.

4900 West Electric Avenue • West Milwaukee, WI 53219 U.S.A.

800-558-8565 • 414-902-6400 • Fax 414-902-6446 • info@eLakeside.com • www.eLakeside.com/foodservice

Models
 4938, 4939
 4943, 4944
 4958, 4959

Handler Series Utility Carts

Stainless Steel Tough Transport® - 1000 Lb. Capacity

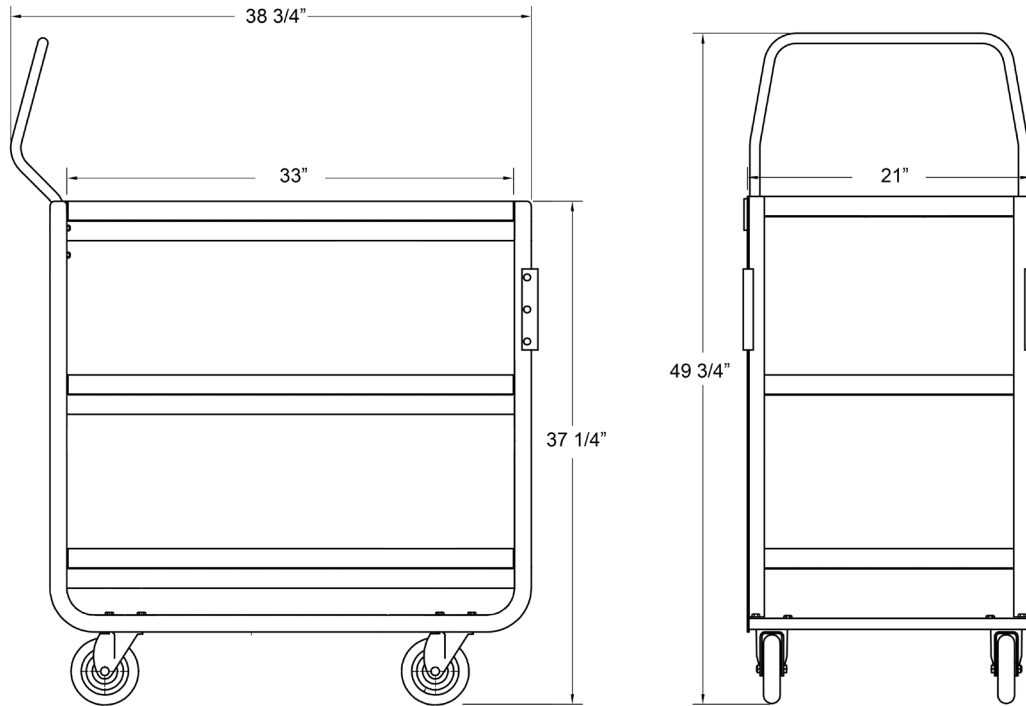

Model 4944

Model Information

Model	# of	Shelf Description		Top Shelf Height	Overall Size*			Case Weight	
		Size	Clearance		L	W	H	Lbs.	(Kg)
4938	2	18" x 27" (457 x 686)	19" (483)	35-3/4" (908)	33" (838)	19-3/4" (502)	49-3/4" (1264)	66	(29.9)
4939	3	18" x 27" (457 x 686)	10" (254)	35-3/4" (908)	33" (838)	19-3/4" (502)	49-3/4" (1264)	80	(36.3)
4943	2	21" x 33" (533 x 838)	21" (533)	35-3/4" (908)	38-3/4" (984)	22-3/4" (578)	49-3/4" (1264)	88	(39.9)
4944	3	21" x 33" (533 x 838)	11-3/8" (289)	35-3/4" (908)	38-3/4" (984)	22-3/4" (578)	49-3/4" (1264)	106	(48.1)
4958	2	21" x 49" (533 x 1245)	21" (533)	35-3/4" (908)	55" (1397)	22-3/4" (578)	49-3/4" (1264)	123	(55.8)
4959	3	21" x 49" (533 x 1245)	11-3/8" (289)	35-3/4" (908)	55" (1397)	22-3/4" (578)	49-3/4" (1264)	150	(68)

Measurements in () denote metric millimeters, unless otherwise specified.
 * Including vertical handle.

Optional Accessories

- Extended perimeter bumper
- Set of 2 each 5" (127 mm) brake casters
- Ground and polished joint welds



Lakeside Manufacturing, Inc.
 4900 West Electric Avenue • West Milwaukee, WI 53219 U.S.A.
 800-558-8565 • 414-902-6400 • Fax 414-902-6446
 info@eLakeside.com • www.eLakeside.com/foodservice