

TECHNICAL DATA SHEET

Customer:

Project:

Date:

Reference:

Design Criteria

Medium	: Glycol (max.%40)
Capacity (pressure < 2 bar)	: 780 l/h
Capacity (pressure > 2 bar)	: 1000 l/h
Max system volume	: 325 m ³
Min. Pressure	: 1 bar-g
Max. pressure	: 6 bar-g
Min. Temperature	: 1°C
Max. Temperature	: 90°C
Ambient temperature	: 1 - 55 °C
Noise level	: 56 db(A)

Connections (flexible)

Inlet / Outlet : 1/2" Female

Testing and Quality Assurance

Running test	: Yes
Test medium	: Water
High Voltage Test	: Yes
Test certificate	: No
CE / UKCA Marking	: Yes
Material Certificates (Structural Parts)	: Yes

Construction Materials

Vessel	: AISI304/Stainless
Fittings / Hoses	: AISI304/Stainless
Pump	: AISI304/Coated cast iron
Deaeration Cap	: Brass
Valve Sealing	: Klingerit Gasket
Cover	: Plastic
Colour	: Black

CA1 Vacuum Degasser 6 Bar Auto-Refill

Item code : 53000109

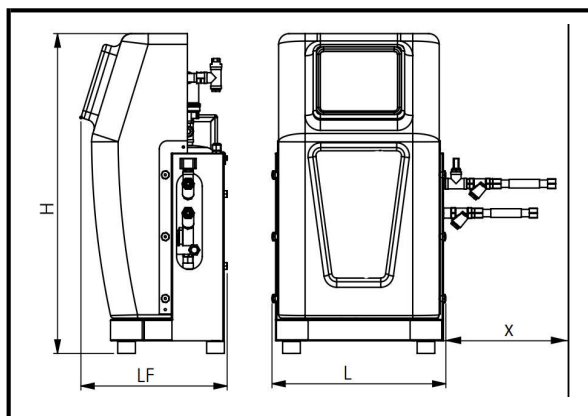

Dimensions

H	: 776 mm
L	: 433 mm
LF	: 386 mm
X	: >500 mm
Dry weight (approx)	: 50 kg

Power Supply

Voltage	: 220 - 240 V
Power consumption	: 0.75 kW
Protection level	: IP54

B.M.S. Contacts

Boiler interlock	: Voltage free
Common fault	: Voltage free
Communication	: licy 3 x 1.5 mm