

Technical Parameters

Size	Dimensions (mm)						
	A	B	C	D	E	F	G
5 L	734	300	230	280	100	200	180
10 L	884	450	230	280	250	350	180
15 L	1,084	650	230	280	450	550	180

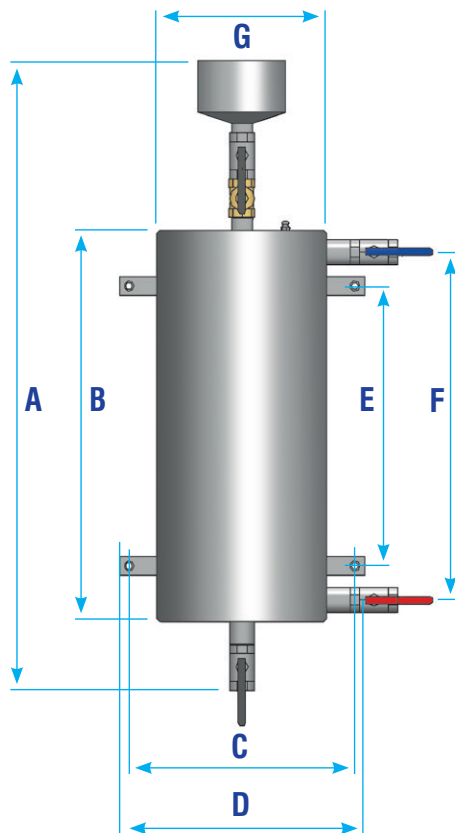

Specification

Vessel: **Stainless steel**
Tundish: **Stainless steel**
Flow/return isolation valves: **1" BSP, Stainless steel**
Drain Valve: **1" BSP, Stainless steel**

Operating Parameters

Maximum working pressure: **10 Bar**
Maximum system temperature: **110° C**
Hydrostatic test pressure: **15 Bar**

Approvals

Designed and manufactured in accordance with the Pressure Equipment Directive 97/23/EU.

Warranty

Fernox covers the product for a warranty period of 2 years as long as it is used in the correct manner and under the terms indicated in the technical specifications listed.

To activate your warranty, please register your product by scanning the QR code.



Fernox, Fernox Ltd
2 Genesis Business Park
Albert Drive, Sheerwater, Woking
Surrey, GU21 5RW, United Kingdom
Tel: +44 (0) 330 100 7750
sales@fernox.com

Fernox, MacDermid Alpha Hungary Kft.
2330 Dunaharaszti, Jedlik Ányos utca 2.
Hungary Tel +36 24 506 110

Fernox
Alpha Assembly Solutions Germany GmbH
Elisabeth-Selbert-Straße 4
40764 Langenfeld, Germany
Tel: +49 21738490313

FM1 Stainless Steel Dosing Pot

Instructions



Introduction

The **Fernox FM1 Stainless Steel Dosing Pot** provides a safe, controlled method of dosing chemicals into heating and chilled water systems with no interruption to the system operation.

The **FM1 Stainless Steel Dosing Pot** is supplied as a complete package with all valves and tundish fitted to minimise time on site for installation. These cost effective, easy to install units facilitate simple, regular on-going maintenance of your heating or chilled water system. The **FM1 Stainless Steel Dosing Pot** features a top-mounted, manual air vent that can be opened during the filling operation to minimise air ingress into the system.

For your safety, each **FM1 Stainless Steel Dosing Pot** is fitted with an integral safety valve that prevents fluid escaping under pressure if the top entry valve is opened before the flow and return valves are closed. Each unit is individually hydrostatically tested to 15 bar prior to despatch.

To cover all requirements, the standard **FM1 Stainless Steel Dosing Pot** range includes three different sized units: 5 litres, 10 litres and 15 litres.

Sizing

The size of dosing pot installed in a system is not critical as multiple doses of chemicals can be added to the system to reach the correct concentration. The benefits of using a smaller unit is that it is easier to physically handle and also allows for more accurate dosing. However, the time on site for performing multiple doses has to be considered; this factor should influence your decision when selecting dosing pots. *Note: Chilled water systems often require large volumes of glycol to be dosed in to the system; a larger dosing pot may be required for chilled water systems.*

The formula below can be used as a guide to help you in your selection:

$$\text{Boiler Power (kW)} \times 12 \text{ Litres/kW} \times 0.01 \text{ (based on 1\% concentration*)} = \text{Volume of chemical required}$$

**Confirm the required concentration level for the chemical being used.*

Example:

$$\text{Boiler Power } 250\text{kW} \times 12\text{kW} \times 0.01 = 30 \text{ litres of chemical}$$

You could use any of the following dosing pots for this installation:

- 5 litre – dose 6 times
- 10 litre – dose 3 times
- 15 litre – dose 2 times

Size	Product Code	Weight
5 L	20002554/0005	12 Kg
10 L	20002554/0010	17 Kg
15 L	20002554/0015	24 Kg

How to use

Isolate the unit

Close all valves.

Drain the unit

Open the drain valve first, followed by the fill valve.

Fill the unit

Close the drain valve and pour dosing chemical in to the unit through the tundish.

Vent the unit

Open the air vent until air has been purged out. Close all opened valves.

Begin dosing

Fully open the inlet and outlet valves slowly.

Complete dosing

Close all valves when dosing has completed. Repeat the above steps if necessary.

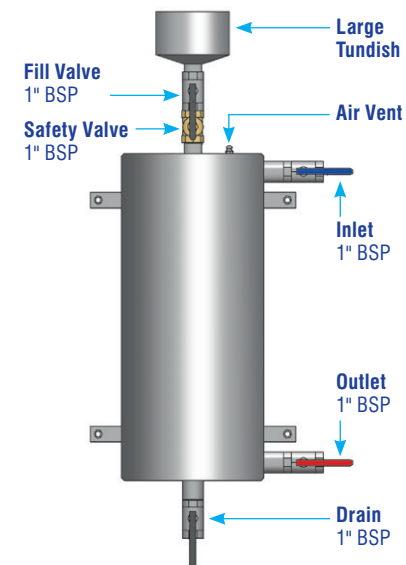

Installation

To ensure a fast, but safe dispersal of the chemical dose, it is important that the unit is installed correctly. Install the unit between the flow and return pipework at the point with the highest differential pressure. Ensure the unit is securely fixed to a wall using the integral wall mounting brackets. Make certain that the drainage point is either piped to waste or that there is suitable space beneath the unit for collection of discharged fluid.

Phase 1

Central heating water is running through a dosing pot.

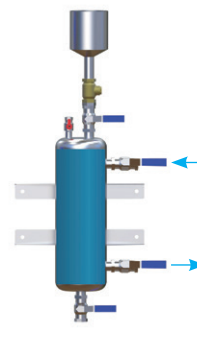

Phase 2

Water is pushed into the heating system.

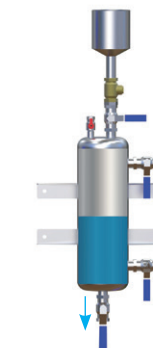

Phase 3

Inhibitor replaces water inside the dosing pot.



Phase 4

Inhibitor is pushed into the central heating system.

