

8. Product dimensions

Fernox CC1 Magnetic Combi Air & Dirt Separator – Standard

Fernox CC1 Magnetic Combi Air & Dirt Separator – High

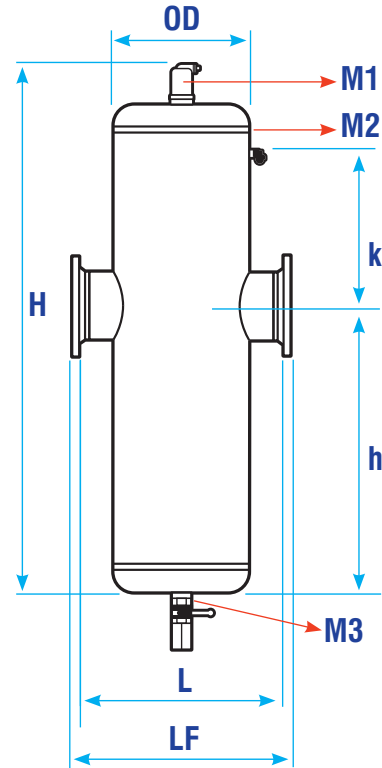
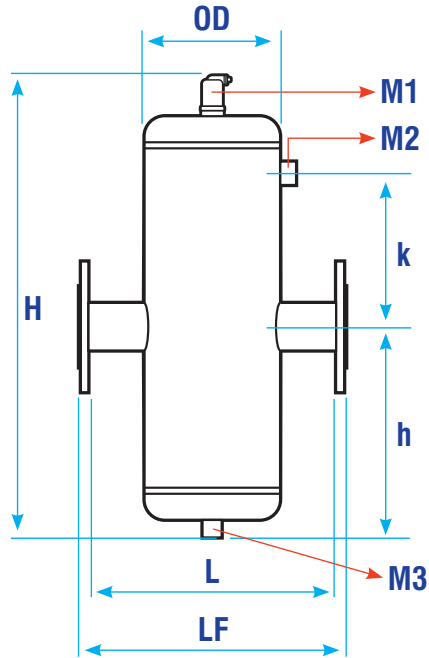

Connection DN	OD mm	L mm	LF mm	Standard flow: Nom. 1.5 m/s Nom. = 1.5 m/s					High flow: Nom. 3 m/s Max = 3 m/s					M1	M2	M3
				H mm	h mm	Max Flow L/s	Max Flow m3/h	Max Flow kPa	H mm	h mm	Max Flow L/s	Max Flow m3/h	Max Flow kPa			
50	168.3	330	350	632	265	3.3	12	3	880	370	5.8	21	11.8	1 3/4"	1/2"	1"
65	168.3	330	350	632	265	6.3	22.5	2.7	880	370	10.0	36	11.6	1 3/4"	1/2"	1"
80	219.1	450	470	791	345	8.3	30	2.9	1110	480	15.0	54	12.4	1 3/4"	1/2"	1"
100	219.1	455	475	791	345	12.5	45	3.7	1110	480	23.3	84	14.6	1 3/4"	1/2"	1"
125	323.9	615	635	1064	480	20.8	75	4.2	1540	700	36.7	132	16.8	1 3/4"	1/2"	
150	323.9	615	635	1064	480	31.3	112.5	4.9	1540	700	52.8	190	19.4	1 3/4"	1/2"	

Operating pressure: 0-10 bar

Fluid Temperature : 0-110 °C

www.fernox.com

FERNOX
MAKES WATER WORK

FERNOX
MAKES WATER WORK

9. Pressure drop chart

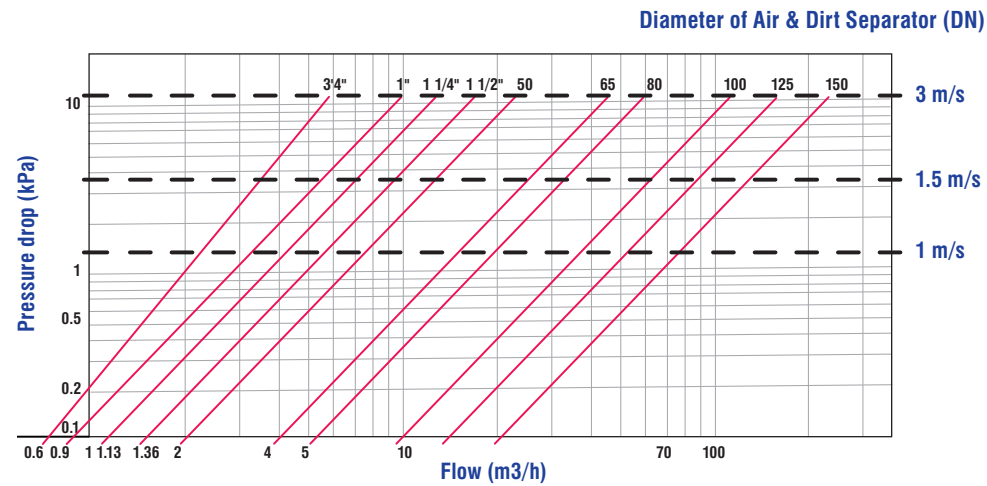

Example:

When the water flow is 70 m3/h pressure drop for the DN 150 CC1 Magnetic Combi Air & Dirt Separator:

- From the 'Flow' axis at 70 m3/h at the point A, move vertically to the CC1 Magnetic Combi Air & Dirt Separator DN 150 curve at point B. When the water flow is 70 m3/h pressure drop for the DN 150 CC1 Magnetic Combi Air & Dirt Separator:
- Move left from point B to meet the 'Pressure Drop' axis at point C, for this example Pressure Drop will be 1 kPa.

www.fernox.com

CC1 Magnetic Combi Air & Dirt Separator

Instructions



CC1 Magnetic Combi Air & Dirt Separator
Standard Flow

CC1 Magnetic Combi Air & Dirt Separator
High Flow



Fernox, Fernox Ltd
2 Genesis Business Park
Albert Drive, Sheerwater, Woking
Surrey, GU21 5RW, United Kingdom
Tel: +44 (0) 330 100 7750
sales@fernox.com

Fernox, MacDermid Alpha Hungary Kft.
2330 Dunaharaszti, Jedlik Ányos utca 2.
Hungary Tel +36 24 506 110

Fernox
Alpha Assembly Solutions Germany GmbH
Elisabeth-Selbert-Straße 4
40764 Langenfeld, Germany
Tel: +49 21738490313

www.fernox.com

1. Introduction

1.1 About the device

The **Fernox CC1 Magnetic Combi Air & Dirt Separator** improves the quality of your installation.

- For an overview of the product, refer to section 2.1.

- For the intended use, refer to section 2.3.

CC1 Magnetic Combi Air & Dirt Separator is designed and manufactured according to the Sound Engineering Practice as stated in the Pressure Equipment Directive (2014/68/EU).

This manual applies to all products listed below.

Product Code	Connection size (DN) code
CC1 Magnetic Combi Air & Dirt Separator Standard Flow	
33006242/0050	050: DN50
33006242/0065	065: DN65
33006242/0080	080: DN80
33006242/0100	100: DN100
33006242/0125	125: DN125
33006242/0150	150: DN150
CC1 Magnetic Combi Air & Dirt Separator High Flow	
33006243/0050	050: DN50
33006243/0065	065: DN65
33006243/0080	080: DN80
33006243/0100	100: DN100
33006243/0125	125: DN125
33006243/0150	150: DN150

1.2. Symbols

Throughout the instructions the following symbols are used:



Warning risk of injury or **caution** risk of damage



Caution risk of burns

2. Overview of the unit

2.1. Intended use

The **CC1 Magnetic Combi Air & Dirt Separator** (fully) automatically removes air, gasses, and (magnetic) dirt from water and water/glycol mixtures.

2.2. Operating conditions

The **CC1 Magnetic Combi Air & Dirt Separator**

is suitable for use in systems filled with water or mixtures of water and glycol up to 50%. The **CC1 Magnetic Combi Air & Dirt Separator** can be used in combination with Fernox chemicals/inhibitors. Please check that the materials in the **CC1 Magnetic Combi Air & Dirt Separator** are compatible with the materials and fluid used in your system. For more information contact your supplier. Operation in combination with other fluids may result in irreparable damage.



Warning

The **CC1 Magnetic Combi Air & Dirt Separator** cannot be used for drinking water, and dangerous or flammable substances, i.e. unit should be used within the limits of the technical specifications as given in chapter 3. If demineralised water is used to fill the system, a quality inhibitor such as **Fernox Protector F1** or **F9** must be used.

2.3. Scope of delivery

- 1 x **CC1 Magnetic Combi Air & Dirt Separator**
- 1 x Instructions
- Quick Start Guide
- Each Quick Start Guide has a QR-scan code with a direct link to this user manual.

3. Technical specifications

3.1. Operating Characteristics

Item	All types
Working pressure (bar-g)	0-10
Working temperature (°C)	0-110
Nominal flow velocity (m/s)	1.5
Maximal flow velocity of high flow speed units (m/s)	3.0
Flange type of flanged units	PN16 (DIN 2633) (EN1092)

3.2. Quality control specifications

3.2.1. Leak test specifications
These are the specifications of the quality control at Fernox.

Item	All types
Test pressure (bar-g)	>15
Test medium	Water and air
Test time (sec.)	240
Approval criterion	No leakage

3.2.2. Functional Test of the Automatic Air Vent

Item	All types
Valve opening test	Full bore venting
Valve closing test	Positive valve closure

3.2.3. Standards

Item	All types
Construction	Pressure Equipment Directive 2014/68/EU – Sound Engineering Practice
Quality, safety and environmental aspects	EN-ISO 9001 EN-ISO 14001 EN-ISO 45001

4. Safety

4.1. Safety Instructions



Warning

- Installation and maintenance may only be carried out by a qualified installer.
- When working on the unit, always ensure there is no pressure in the unit, let it cool down and remove the water from the unit. This is not applicable when draining dirt from the unit.



Warning

- Do not touch the unit or the pipework when the system is in operation. The surfaces may be hot and cause burns.



Caution

- Always install the unit body vertically, with the automatic air vent (if available) on top and drain valve at the bottom.

5. Installation and commissioning

5.1. Installation conditions

- Install the unit in a frost-free, well-ventilated area.
- Install the unit in accordance with the local guidelines and rules.
- Install the unit stress free and with the body in vertical position.
- Do not use the unit as a support for pipe work
- It is not allowed to weld the unit to the pipework or other external items unless the unit is specifically designed to be welded into the pipework.
- It is not allowed to modify the unit.
- Apply the separately supplied product labels if the labels on the product are not visible; for instance, after the unit has been insulated.
- The unit operates independent of the flow direction.
- Do not obstruct the automatic air vent (if available) and make sure that the automatic air vent is always easily accessible.
- If a drainpipe is fitted, make sure that this pipe is fitted stress and vibration free to the drain valve. Preferably, a flexible pipe or pipe parts should be used (e.g. a hose).
- Do not obstruct the vent valve and keep all valves accessible.

5.2. Installing the unit

5.2.1 Mounting the unit

- Attach the pipework to the to the unit. Make sure that the unit is installed stress free.
- Tighten the fasteners to the correct torque value of the pipework.

5.2.2 Installing the Drain Valve

NOTE: Make sure that there is enough space to operate the valve.



The **Fernox CC1 Magnetic Combi Air & Dirt Separator** is a combination of deaerator and dirt separator which removes circulating air and micro bubbles also dirt effectively. In heating systems this should be in the flow and installed after the boiler. In chilled water systems the unit must be located in the return close to the chiller.

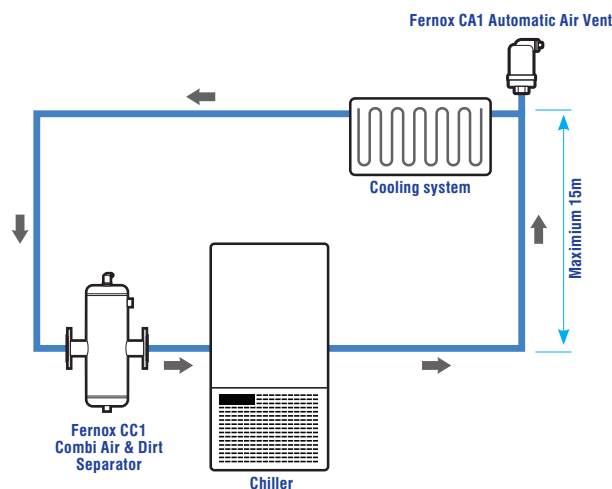
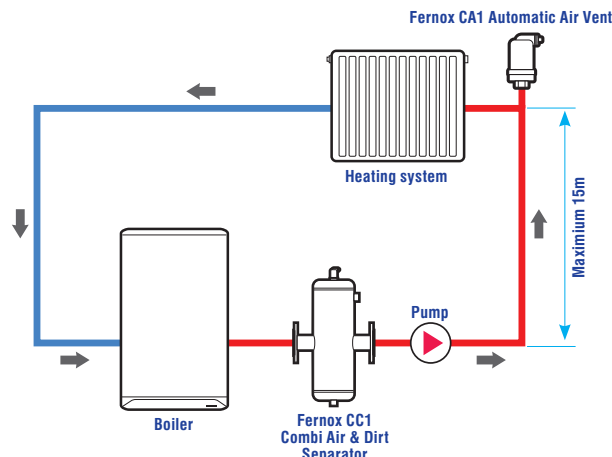

Caution

5.3. Commissioning

If a cap R ½ was installed on the automatic air vent for the system test, make sure that cap R ½ is removed before the commissioning of the system. The system must be commissioned and running to verify if the unit works properly. At the first use, the automatic air vent (if applicable) might temporarily drip a bit of moist, but that is not a problem. When the system is running, do the checks as follows:

- Leak check in 3.2.1.

6. Preventative maintenance

6.1 Maintenance schedule for the Fernox CC1 Magnetic Combi Air & Dirt Separator

Task

Drain the dirt from the unit.

Interval

The first month after installation and after that on a regular basis, dependent on the amount of dirt in the system.

6.2. Drain the dirt from the unit



Warning

- The main body and the piping may be hot.
- Hot water or steam may escape during the procedure.

- Remove the safety plug.
- Pull down the magnet using the handle.
- Connect a hose to the drain valve. Make sure that the hose is connected to a drain.
- Move the magnet through the unit.
 - Gradually pull down the magnet.

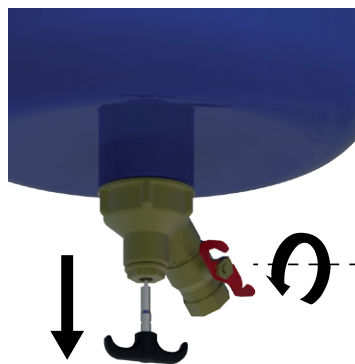

Caution

- Caution – Do not use force.**
- Gradually let the handle return to the original position.
- Repeat the steps one or two times for the best result.

- Gradually open the drain valve for a short period.

Note: Restrict the amount of water that gets drained off.

- Close the drain valve.
- Disconnect the hose from the drain valve.
- Install the safety plug.
- Check the system pressure. If it is necessary, refill the system.

6.3. Clean or replace the CC1 Magnetic Combi Air & Dirt Separator Standard and High Flow



Caution

- Make sure that there is no pressure in the unit
- Make sure that the unit has cooled down.
- Make sure that the unit is drained prior to opening the unit
- Do not use corrosive chemicals.
- Make sure that the unit is correctly supported.
 - The **CC1 Magnetic Combi Air & Dirt Separator** is supported by the bottom of the separator.
 - CC1 Magnetic Combi Air & Dirt Separator** bundle may tumble over.
 - In some cases the **CC1 Magnetic Combi Air & Dirt Separator** may be affected by corrosion or fouling, which may reduce the mechanical strength.
 - CC1 Magnetic Combi Air & Dirt Separator** may be considerably heavier due to clogging dirt.

6.3.1. Prepare the unit for cleaning or replacement

- Remove the pressure from the unit.
- Let the unit cool down.
- Support the bottom and **CC1 Magnetic Combi Air & Dirt Separator** with appropriate supports, hoisting or lifting devices.

7. Warranty

Fernox covers the product for a warranty period of 2 years as long as it is used in the correct manner and under the terms indicated in the technical specifications listed.

To activate your warranty, please register your product by scanning the QR code.

