



HINGES

ALUMINUM & STAINLESS
CONTINUOUS HINGES





CONTINUOUS HINGE INDEX:

	Page
Aluminum:	
Concealed	CH3 - CH8
Electric Thru-Wire.....	CH15, CH16
EPT Prep.....	CH17
Full Surface.....	CH9 - CH10
Half Mortise	CH14
Half Surface.....	CH11 - CH13
Swing Clear	CH8, CH10, CH13
Anti-Ligature Hospital Tip.....	CH18

Stainless Steel:

Concealed	CH18
Electric Thru-Wire, Electric Power Transfer Prep.....	CH26
Full Surface.....	CH23
Full Wrap Edge Guard, Concealed.....	CH20
Half Mortise	CH24
Half Mortise with Half Wrap Edge Guard.....	CH25
Half Wrap Edge Guard, Concealed.....	CH21
Swing Clear with Half Wrap Edge Guard.....	CH22

NUMERICAL INDEX:

ALHT.....	CH18	HD2100.....	CH10	SS300.....	CH19
EPT PREP.....	CH17, CH26	HD2400.....	CH6	SS302.....	CH23
ETW8.....	CH15, CH26	HD2700.....	CH7	SS304.....	CH24
ETW8-Molex.....	CH15	HD4100.....	CH8	SS305.....	CH20
ETW12.....	CH16	HD4200.....	CH13	SS306.....	CH25
ETW12-Molex.....	CH16	HD5200.....	CH14	SS311.....	CH22
HD1100.....	CH3	HD5300.....	CH11	SS315.....	CH21
HD1400.....	CH5	HD5400.....	CH12	TIPIT® LG.....	CH18
HD1800.....	CH4	HD5700.....	CH9		

CONTINUOUS GEARED HINGES

FASTENERS, RATINGS, SYMBOLS, REQUIREMENTS

FASTENERS



#12 x 1 1/16"
FH U/C TEK MS



#12 x 3/4"
PH TEK MS



Phillips
Head



Torx Head
(optional)

FH = Flat Head
PH = Pan Head
U/C = Undercut



#12 x 1 1/2" Wood Screw

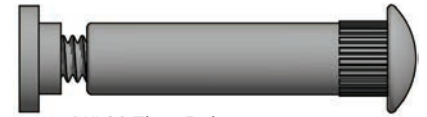

1/4"-20 Thru-Bolt



POSITIVE PRESSURE - CERTIFIED by UL to ANSI/UL10C. Complies with IBC, NFPA 80 and NFPA 252 for application to Hollow Metal and Wood Fire Doors rated up to to 90 minutes. See individual products for maximum door size.



ANSI/BHMA Certified. Certified hinges comply with American National Standard for Continuous Hinges ANSI/BHMA A156.26 and are listed in the BHMA Certified Products Directory.

ANSI/BHMA

The following explains ANSI/BHMA numbers which identify material and type of products. Look for the BHMA certified logo next to the product in our catalog. For a complete listing refer to the BHMA Certified Products Directory online at www.buildershardware.com.

ANSI/BHMA A156.26 American National Standard for Continuous Hinges

1 Product Section	2 Material	3 Product Type	4 Electrical Modifications	5 Door Weight (lbs.)	6 Grade	7 Hinge Type
"A" designates Hinges	1. Brass Bronze 3. Aluminum 5. Stainless Steel 8. Steel	1. Edge Mounted 2. Half Edge Mounted 3. Full Surface 4. Half Surface 5. Swing Clear 6. Raised Barrel 7. Wide Throw 0. Other	0. None 1. Concealed Wire Transfer 2. Monitor 3. Power Transfer 4. Other	1. 150 2. 300 3. 600 4. 1200	1. Grade 1 2. Grade 2 3. Grade 3	B. Barrel G. Geared

LEED GREEN BUILDING

The LEED (Leadership in Energy and Environmental Design) Green Building Rating System® is a national standard for developing high-performance, sustainable buildings developed by the U. S. Green Building Council. Our current LEED letter containing LEED qualification information for all our products is available at ngp.com.

Environmental Product Declarations (EPD) prepared and certified by an Independent Laboratory based on Life Cycle Assessments (LCA) of our products and Health Product Declarations (HPD) may be viewed on our website ngp.com.

National Guard Products sustainability report may be viewed on our website ngp.com/report.

Contact us regarding our end of use product recycling program.

BUY AMERICAN REQUIREMENTS

Over 99% of our products are produced in the United States as a domestic construction material, as defined in the Buy American Act (BAA) of March 1933 and amended by the Buy American Act of 1988 and FAR 52.225-9. A Buy American Certificate may be obtained on our website ngp.com.

CONTINUOUS GEARED HINGE

CONCEALED

NO DOOR INSET, FLUSH MOUNT FOR 1 3/4" DOORS

HD1100 HD1100-LL

Continuous geared aluminum hinges run the full height of the door, evenly distributing the weight of the door along the full height of the frame. Ideal for high-frequency and heavy-weight doors in new construction and retrofit applications.

- ▶ Aluminum alloy 6063-T6; Anodized after machining
- ▶ Specially designed involute intermeshing gears
- ▶ Proprietary Teflon infused self-lubricating wear resistant bearings
- ▶ No hinge reinforcement necessary except on extremely heavy, extremely high-frequency or extra-wide doors
- ▶ Lifetime of the door opening warranty
- ▶ #12-24 TEK MS
- ▶ "LL" model for doors up to 1,000 lbs. features lead-lined dual row hole pattern
- ▶ Standard lengths: 83", 85", 95", 119"

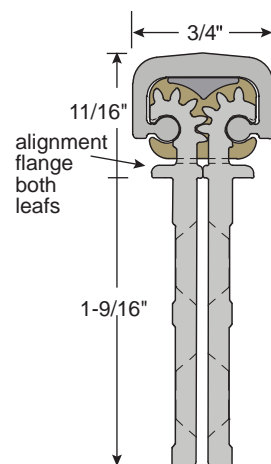

Available Options

- ▶ #12 x 1 1/2" Wood Screws
- ▶ Torx Security TEK Screws
- ▶ 1 1/2" Torx Security Wood Screws
- ▶ Cut to Net Length
- ▶ Anti-Ligature Hospital Tip - Specify "ALHT"
- ▶ Dutch Door Prep - Order Form Available at ngp.com
- ▶ Electric Through Wire Center Section with 8 Wires - Specify "ETW8" Order Form Available at ngp.com
- ▶ Electronic Power Transfer Prep - Specify "EPT" Order Form Available at ngp.com

Finishes:

A - Anodized Aluminum

DKB - Dark Bronze/Black Anodized



Fire-rated 90-minute on hollow metal (except steel stiffened) or wood door leaves up to 4'0" x 8'0" and steel stiffened doors up to 4'0" x 7'2"



ANSI/BHMA Certified to A156.26 American National Standard for Continuous Hinges:
Grade 1 - 600 lb. Door



CONTINUOUS GEARED HINGE

CONCEALED

1/8" DOOR INSET, FOR 1 3/4" DOORS

HD1800 HD1800-LL

Continuous geared aluminum hinges run the full height of the door, evenly distributing the weight of the door along the full height of the frame. Ideal for high-frequency and heavy-weight doors in new construction and retrofit applications.

- Aluminum alloy 6063-T6; Anodized after machining
- Specially designed involute intermeshing gears
- Proprietary Teflon infused self-lubricating wear resistant bearings
- No hinge reinforcement necessary except on extremely heavy, extremely high-frequency or extra-wide doors
- Lifetime of the door opening warranty
- #12-24 TEK MS
- "LL" model for doors up to 1,000 lbs. features lead-lined dual row hole pattern
- Standard lengths: 83", 85", 95", 119"

Available Options

- #12 x 1 1/2" Wood Screws
- Torx Security TEK Screws
- 1 1/2" Torx Security Wood Screws
- Cut to Net Length - Specify Door Handing
- Anti-Ligature Hospital Tip - Specify "ALHT" and Door Handing
- Dutch Door Prep - Order Form Available at ngp.com
- Electronic Power Transfer Prep - Specify "EPT" Order Form Available at ngp.com

Finishes:

- A - Anodized Aluminum
- DKB - Dark Bronze/Black Anodized



Fire-rated 90-minute on hollow metal (except steel stiffened) or wood door leaves up to 4'0" x 8'0" and steel stiffened doors up to 4'0" x 7'2"



ANSI/BHMA Certified to A156.26 American National Standard for Continuous Hinges:
Grade 1 - 600 lb. Door

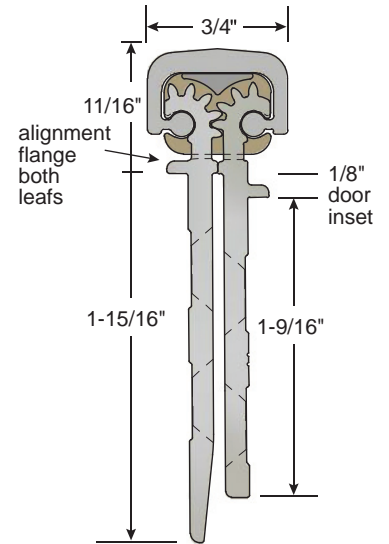

Frame leaf covers butt hinge preps



CONTINUOUS GEARED HINGE

CONCEALED

1/16" DOOR INSET, FOR 1 3/4" DOORS

HD1400 HD1400-LL

Continuous geared aluminum hinges run the full height of the door, evenly distributing the weight of the door along the full height of the frame. Ideal for high-frequency and heavy-weight doors in new construction and retrofit applications.

- ▶ Aluminum alloy 6063-T6; Anodized after machining
- ▶ Specially designed involute intermeshing gears
- ▶ Proprietary Teflon infused self-lubricating wear resistant bearings
- ▶ No hinge reinforcement necessary except on extremely heavy, extremely high-frequency or extra-wide doors
- ▶ Lifetime of the door opening warranty
- ▶ #12-24 TEK MS
- ▶ "LL" model for doors up to 1,000 lbs. features lead-lined dual row hole pattern
- ▶ Standard lengths: 83", 85", 95", 119"

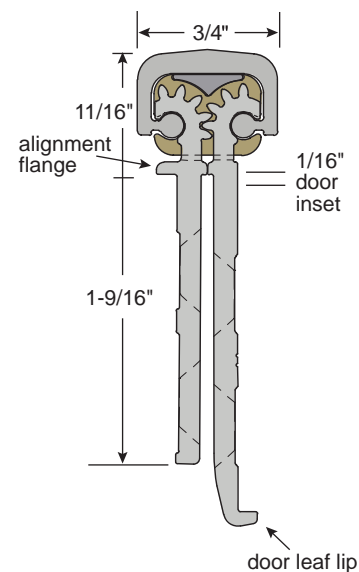

Narrow frame leaf allows
NGP 2525 bulb seal

Available Options

- ▶ #12 x 1 1/2" Wood Screws
- ▶ Torx Security TEK Screws
- ▶ 1 1/2" Torx Security Wood Screws
- ▶ Cut to Net Length - Specify Door Handing
- ▶ Anti-Ligature Hospital Tip - Specify "ALHT" and Door Handing
- ▶ Dutch Door Prep - Order Form Available at ngp.com
- ▶ Electronic Power Transfer Prep - Specify "EPT" Order Form Available at ngp.com

Finishes:

A - Anodized Aluminum

DKB - Dark Bronze/Black Anodized



Fire-rated 90-minute on hollow metal (except steel stiffened) or wood door leaves up to 4'0" x 8'0" and steel stiffened doors up to 4'0" x 7'2"



ANSI/BHMA Certified to A156.26 American National Standard for Continuous Hinges:
Grade 1 - 600 lb. Door



CONTINUOUS GEARED HINGE

CONCEALED

1/16" DOOR INSET, FOR 1 3/4" DOORS

HD2400 HD2400-LL

Continuous geared aluminum hinges run the full height of the door, evenly distributing the weight of the door along the full height of the frame. Ideal for high-frequency and heavy-weight doors in new construction and retrofit applications.

- ▶ Aluminum alloy 6063-T6; Anodized after machining
- ▶ Specially designed involute intermeshing gears
- ▶ Proprietary Teflon infused self-lubricating wear resistant bearings
- ▶ No hinge reinforcement necessary except on extremely heavy, extremely high-frequency or extra-wide doors
- ▶ Lifetime of the door opening warranty
- ▶ #12-24 TEK MS
- ▶ "LL" model for doors up to 1,000 lbs. features lead-lined dual row hole pattern
- ▶ Standard lengths: 83", 85", 95", 119"

Available Options

- ▶ #12 x 1 1/2" Wood Screws
- ▶ Torx Security TEK Screws
- ▶ 1 1/2" Torx Security Wood Screws
- ▶ Cut to Net Length - Specify Door Handing
- ▶ Anti-Ligature Hospital Tip - Specify "ALHT" and Door Handing
- ▶ Dutch Door Prep - Order Form Available at ngp.com
- ▶ Electric Through Wire Center Section with 8 Wires - Specify "ETW8" Order Form Available at ngp.com
- ▶ Electronic Power Transfer Prep - Specify "EPT" Order Form Available at ngp.com

Finishes:

A - Anodized Aluminum
DKB - Dark Bronze/Black Anodized



Fire-rated 90-minute on hollow metal (except steel stiffened) or wood door leaves up to 4'0" x 8'0" and steel stiffened doors up to 4'0" x 7'2"



ANSI/BHMA Certified to A156.26 American National Standard for Continuous Hinges:
Grade 1 - 600 lb. Door

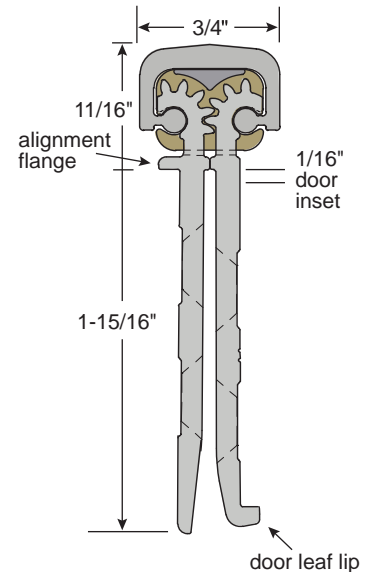

Frame leaf covers butt hinge preps



CONTINUOUS GEARED HINGE

CONCEALED

NO DOOR INSET, FLUSH MOUNT FOR 2" TO 2 1/4" DOORS

HD2700 HD2700-LL

Continuous geared aluminum hinges run the full height of the door, evenly distributing the weight of the door along the full height of the frame. Ideal for high-frequency and heavy-weight doors in new construction and retrofit applications.

- ▶ Aluminum alloy 6063-T6; Anodized after machining
- ▶ Specially designed involute intermeshing gears
- ▶ Proprietary Teflon infused self-lubricating wear resistant bearings
- ▶ No hinge reinforcement necessary except on extremely heavy, extremely high-frequency or extra-wide doors
- ▶ Lifetime of the door opening warranty
- ▶ #12-24 TEK MS
- ▶ "LL" model for doors up to 1,000 lbs. features lead-lined dual row hole pattern
- ▶ Standard lengths: 83", 85", 95", 119"

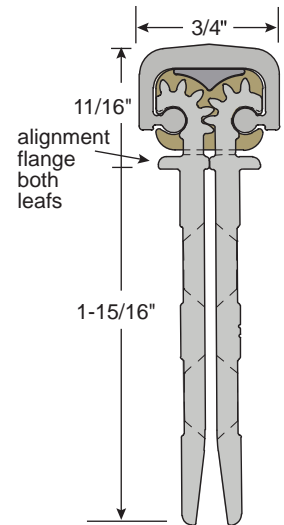

Frame leaf covers butt hinge preps

Available Options

- ▶ #12 x 1 1/2" Wood Screws
- ▶ Torx Security TEK Screws
- ▶ 1 1/2" Torx Security Wood Screws
- ▶ Cut to Net Length
- ▶ Anti-Ligature Hospital Tip - Specify "ALHT"
- ▶ Dutch Door Prep - Order Form Available at ngp.com
- ▶ Electric Through Wire Center Section with 8 Wires - Specify "ETW8" Order Form Available at ngp.com
- ▶ Electronic Power Transfer Prep - Specify "EPT" Order Form Available at ngp.com

Finishes:

A - Anodized Aluminum
DKB - Dark Bronze/Black Anodized



Fire-rated 90-minute on hollow metal (except steel stiffened) or wood door leaves up to 4'0" x 8'0" and steel stiffened doors up to 4'0" x 7'2"



ANSI/BHMA Certified to A156.26 American National Standard for Continuous Hinges:
Grade 1 - 600 lb. Door



CONTINUOUS GEARED HINGE

CONCEALED SWING CLEAR

1/16" DOOR INSET FOR 1 3/4" DOORS

HD4100 HD4100-LL

Continuous geared aluminum hinges run the full height of the door, evenly distributing the weight of the door along the full height of the frame. Ideal for high-frequency and heavy-weight doors in new construction and retrofit applications.

- ▶ Aluminum alloy 6063-T6; Anodized after machining
- ▶ Specially designed involute intermeshing gears
- ▶ Proprietary Teflon infused self-lubricating wear resistant bearings
- ▶ No hinge reinforcement necessary except on extremely heavy, extremely high-frequency or extra-wide doors
- ▶ Lifetime of the door opening warranty
- ▶ #12-24 TEK MS
- ▶ "LL" model for doors up to 1,000 lbs. features lead-lined dual row hole pattern
- ▶ Standard lengths: 83", 85", 95", 119"

Available Options

- ▶ #12 x 1 1/2" Wood Screws
- ▶ Torx Security TEK Screws
- ▶ 1 1/2" Torx Security Wood Screws
- ▶ Cut to Net Length - Specify Door Handing
- ▶ Anti-Ligature Hospital Tip - Specify "TIPIT® LG"
- ▶ Dutch Door Prep - Order Form Available at ngp.com
- ▶ Electronic Power Transfer Prep - Specify "EPT" Order Form Available at ngp.com

Finishes:

- A - Anodized Aluminum
- DKB - Dark Bronze/Black Anodized



Fire-rated 90-minute on hollow metal (except steel stiffened) or wood door leaves up to 4'0" x 8'0" and steel stiffened doors up to 4'0" x 7'2"



ANSI/BHMA Certified to A156.26 American National Standard for Continuous Hinges:
Grade 1 - 600 lb. Door

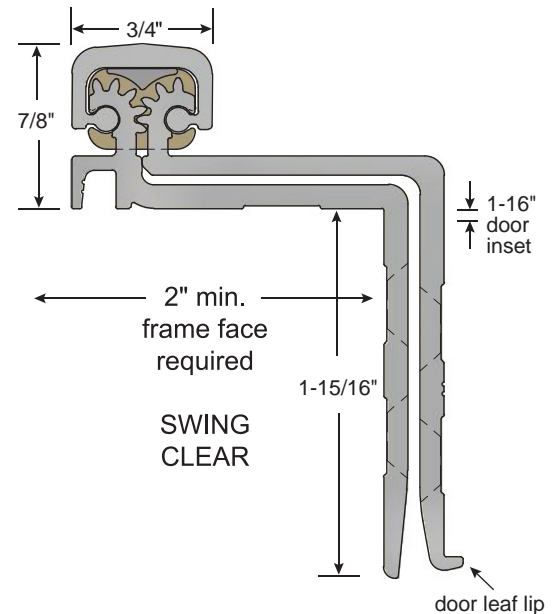

Frame leaf covers butt hinge preps



CONTINUOUS GEARED HINGE

FULL SURFACE

1/16" DOOR INSET FOR 1 3/4" TO 2 1/4" DOORS

HD5700

Continuous geared aluminum hinges run the full height of the door, evenly distributing the weight of the door along the full height of the frame. Ideal for high-frequency and heavy-weight doors in new construction and retrofit applications.

- ▶ Aluminum alloy 6063-T6; Anodized after machining
- ▶ Specially designed involute intermeshing gears
- ▶ Proprietary Teflon infused self-lubricating wear resistant bearings
- ▶ No hinge reinforcement necessary except on extremely heavy, extremely high-frequency or extra-wide doors
- ▶ Lifetime of the door opening warranty
- ▶ Frame leaf: #12-24 TEK flat head MS
- ▶ Door leaf: #12-24 TEK pan head MS and 1/4"-20 thru-bolts
- ▶ Standard lengths: 83", 85", 95", 119"

Available Options

- ▶ #12 x 1 1/2" Wood Screws
- ▶ Torx Security TEK & T.B. M.S.
- ▶ 1 1/2" Torx Security Wood Screws
- ▶ Cut to Net Length - Specify Door Handing
- ▶ Anti-Ligature Hospital Tip - Specify "TIPIT® LG"
- ▶ Dutch Door Prep - Order Form Available at ngp.com

Finishes:

A - Anodized Aluminum
DKB - Dark Bronze/Black Anodized



Fire-rated 90-minute on hollow metal (except steel stiffened) or wood door leaves up to 4'0" x 7'2"



ANSI/BHMA Certified to A156.26 American National Standard for Continuous Hinges:
Grade 1 - 600 lb. Door

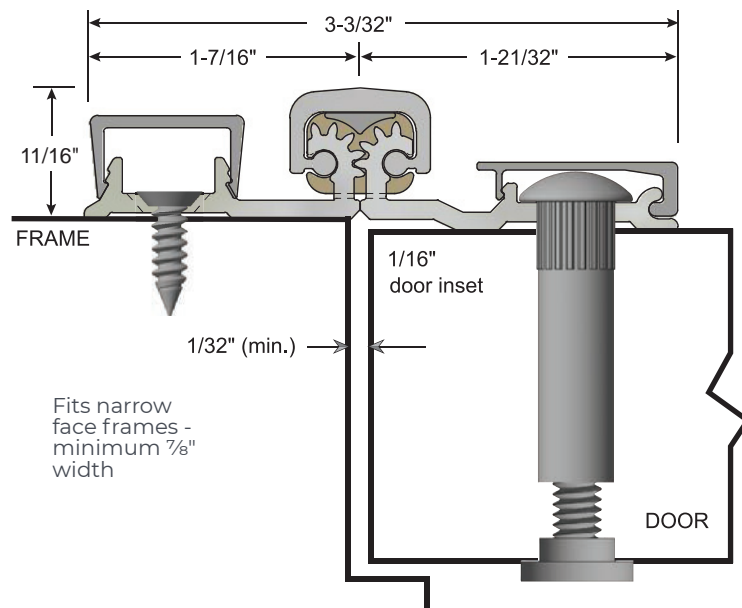

Concealed fastener covers on both leaves

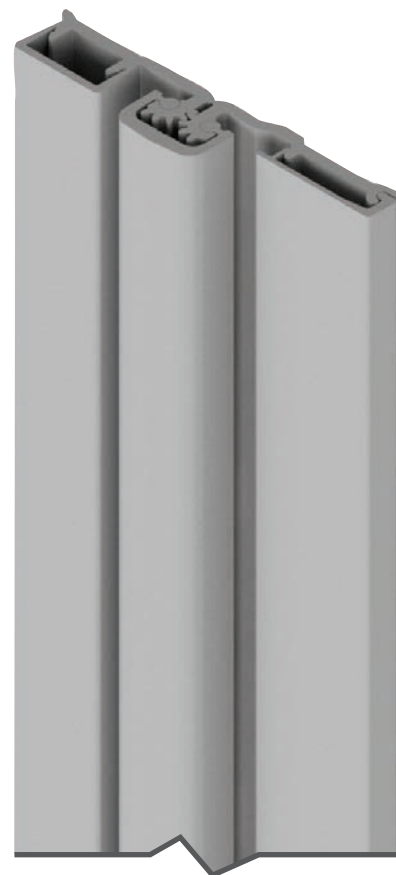

CONTINUOUS GEARED HINGE

FULL SURFACE SWING CLEAR

1/32" DOOR INSET FOR 1 3/4" TO 2 1/4" DOORS

HD2100

Continuous geared aluminum hinges run the full height of the door, evenly distributing the weight of the door along the full height of the frame. Ideal for high-frequency and heavy-weight doors in new construction and retrofit applications.

- ▶ Aluminum alloy 6063-T6; Anodized after machining
- ▶ Specially designed involute intermeshing gears
- ▶ Proprietary Teflon infused self-lubricating wear resistant bearings
- ▶ No hinge reinforcement necessary except on extremely heavy, extremely high-frequency or extra-wide doors
- ▶ Lifetime of the door opening warranty
- ▶ Frame leaf: #12-24 TEK flat head MS
- ▶ Door leaf: #12-24 TEK pan head MS and 1/4"-20 thru-bolts
- ▶ Standard lengths: 83", 85", 95", 119"

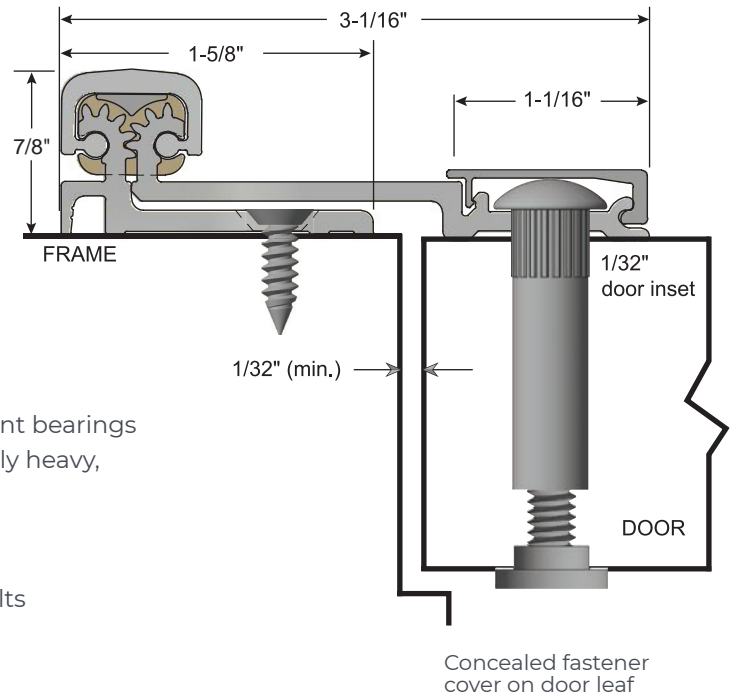

Available Options

- ▶ #12 x 1 1/2" Wood Screws
- ▶ Torx Security TEK & T.B. M.S.
- ▶ 1 1/2" Torx Security Wood Screws
- ▶ Cut to Net Length - Specify Door Handing
- ▶ Anti-Ligature Hospital Tip - Specify "TIPIT® LG"
- ▶ Dutch Door Prep - Order Form Available at ngp.com

Finishes:

- A - Anodized Aluminum
- DKB - Dark Bronze/Black Anodized



Fire-rated 90-minute on hollow metal (except steel stiffened) or wood door leaves up to 4'0" x 7'2"



ANSI/BHMA Certified to A156.26 American National Standard for Continuous Hinges:
Grade 1 - 600 lb. Door



CONTINUOUS GEARED HINGE

HALF SURFACE

3/32" DOOR INSET FOR 1 3/4" TO 2 1/4" DOORS

HD5300

Continuous geared aluminum hinges run the full height of the door, evenly distributing the weight of the door along the full height of the frame. Ideal for high-frequency and heavy-weight doors in new construction and retrofit applications.

- ▶ Aluminum alloy 6063-T6; Anodized after machining
- ▶ Specially designed involute intermeshing gears
- ▶ Proprietary Teflon infused self-lubricating wear resistant bearings
- ▶ No hinge reinforcement necessary except on extremely heavy, extremely high-frequency or extra-wide doors
- ▶ Lifetime of the door opening warranty
- ▶ Frame leaf: #12-24 TEK flat head MS
- ▶ Door leaf: #12-24 TEK pan head MS and 1/4"-20 thru-bolts
- ▶ Standard lengths: 83", 85", 95", 119"

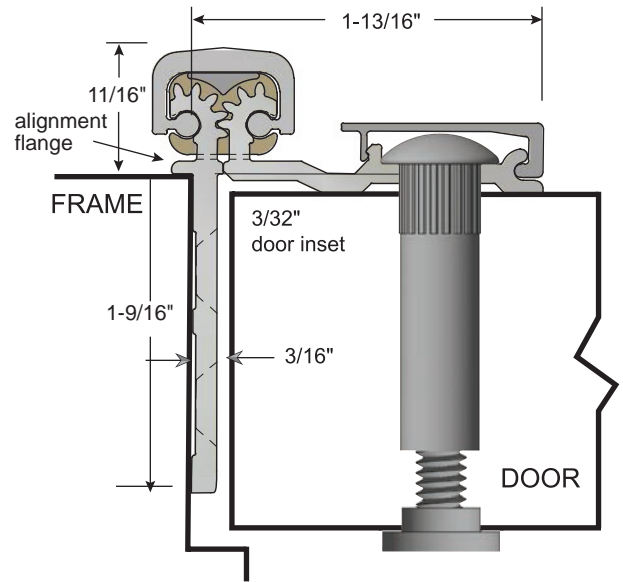

Narrow frame leaf allows NGP 2525 bulb seal
Concealed fastener cover on door leaf

Available Options

- ▶ #12 x 1 1/2" Wood Screws
- ▶ Torx Security TEK & T.B. M.S.
- ▶ 1 1/2" Torx Security Wood Screws
- ▶ Cut to Net Length - Specify Door Handing
- ▶ Anti-Ligature Hospital Tip - Specify "TIPIT® LG"
- ▶ Dutch Door Prep - Order Form Available at ngp.com
- ▶ Electronic Power Transfer Prep - Specify "EPT" Order Form Available at ngp.com

Finishes:

A - Anodized Aluminum

DKB - Dark Bronze/Black Anodized



Fire-rated 90-minute on hollow metal (except steel stiffened) or wood door leaves up to 4'0" x 7'2"



ANSI/BHMA Certified to A156.26 American National Standard for Continuous Hinges:
Grade 1 - 600 lb. Door



CONTINUOUS GEARED HINGE

HALF SURFACE

3/32" DOOR INSET FOR 1 3/4" TO 2 1/4" DOORS

HD5400

Continuous geared aluminum hinges run the full height of the door, evenly distributing the weight of the door along the full height of the frame. Ideal for high-frequency and heavy-weight doors in new construction and retrofit applications.

- ▶ Aluminum alloy 6063-T6; Anodized after machining
- ▶ Specially designed involute intermeshing gears
- ▶ Proprietary Teflon infused self-lubricating wear resistant bearings
- ▶ No hinge reinforcement necessary except on extremely heavy, extremely high-frequency or extra-wide doors
- ▶ Lifetime of the door opening warranty
- ▶ Frame leaf: #12-24 TEK flat head MS
- ▶ Door leaf: #12-24 TEK pan head MS and 1/4"-20 thru-bolts
- ▶ Standard lengths: 83", 85", 95", 119"

Available Options

- ▶ #12 x 1 1/2" Wood Screws
- ▶ Torx Security TEK & T.B. M.S.
- ▶ 1 1/2" Torx Security Wood Screws
- ▶ Cut to Net Length - Specify Door Handing
- ▶ Anti-Ligature Hospital Tip - Specify "TIPIT® LG"
- ▶ Dutch Door Prep - Order Form Available at ngp.com
- ▶ Electronic Power Transfer Prep - Specify "EPT" Order Form Available at ngp.com

Finishes:

- A - Anodized Aluminum
- DKB - Dark Bronze/Black Anodized



Fire-rated 90-minute on hollow metal (except steel stiffened) or wood door leafs up to 4'0" x 7'2"



ANSI/BHMA Certified to A156.26 American National Standard for Continuous Hinges:
Grade 1 - 600 lb. Door

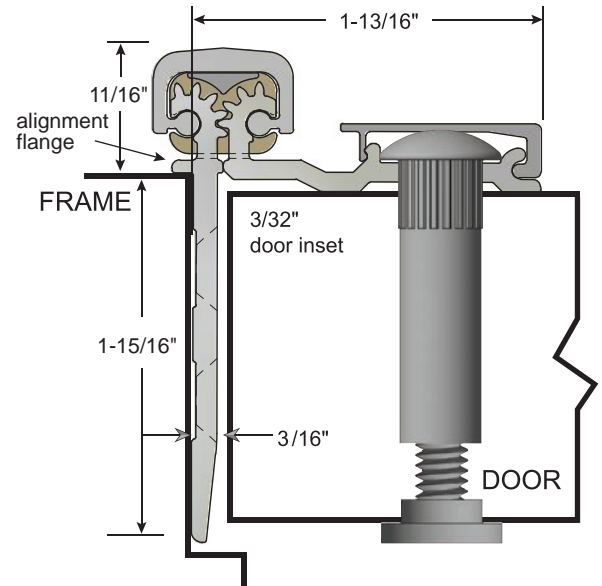

Frame leaf covers butt hinge preps
Concealed fastener cover on door leaf



CONTINUOUS GEARED HINGE

HALF MORTISE

NO DOOR INSET, FLUSH MOUNT FOR 1 3/4" DOORS

HD5200

Continuous geared aluminum hinges run the full height of the door, evenly distributing the weight of the door along the full height of the frame. Ideal for high-frequency and heavy-weight doors in new construction and retrofit applications.

- ▶ Aluminum alloy 6063-T6; Anodized after machining
- ▶ Specially designed involute intermeshing gears
- ▶ Proprietary Teflon infused self-lubricating wear resistant bearings
- ▶ No hinge reinforcement necessary except on extremely heavy, extremely high-frequency or extra-wide doors
- ▶ Lifetime of the door opening warranty
- ▶ #12-24 TEK MS
- ▶ Standard lengths: 83", 85", 95", 119"

Available Options

- ▶ #12 x 1 1/2" Wood Screws
- ▶ Torx Security TEK Screws
- ▶ 1 1/2" Torx Security Wood Screws
- ▶ Cut to Net Length - Specify Door Handing
- ▶ Anti-Ligature Hospital Tip - Specify "TIPIT® LG"
- ▶ Dutch Door Prep - Order Form Available at ngp.com
- ▶ Electronic Power Transfer Prep - Specify "EPT" Order Form Available at ngp.com

Finishes:

- A - Anodized Aluminum
- DKB - Dark Bronze/Black Anodized



Fire-rated 90-minute on hollow metal (except steel stiffened) or wood door leaves up to 4'0" x 7'2"



ANSI/BHMA Certified to A156.26 American National Standard for Continuous Hinges:
Grade 1 - 600 lb. Door

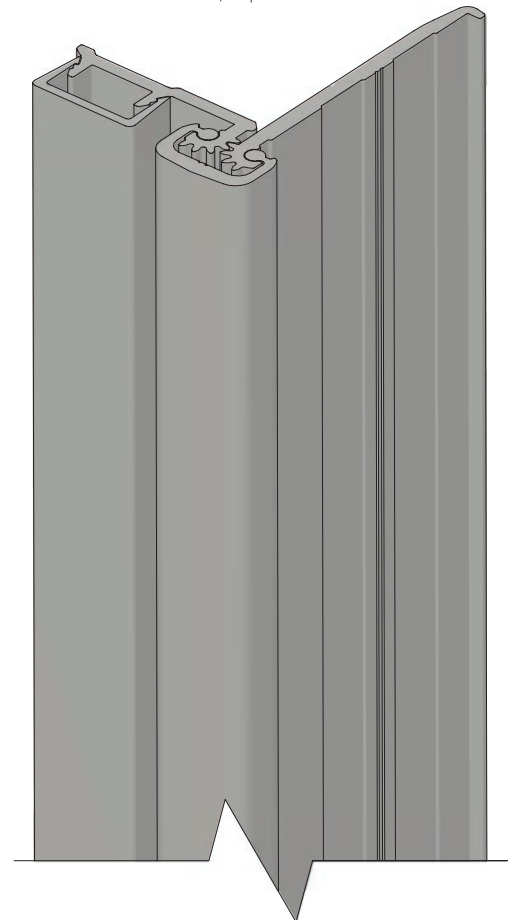
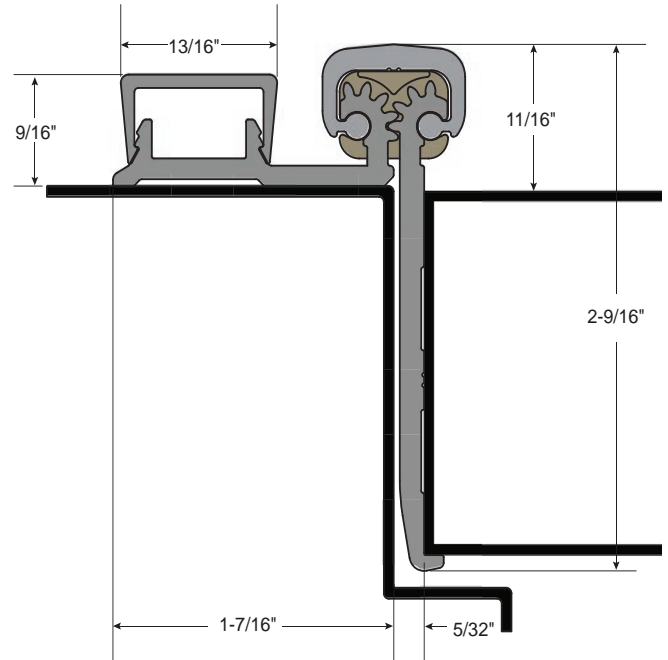

ELECTRIC THRU-WIRE

ETW8

Eight Wire Electric Thru-Wire

Transfers Electric Power Through the Hinge to Power Certain Types of Electronic Builders Hardware.

REMOVABLE ELECTRIC HINGE SECTION

- ▶ 8 Wires, 28 AWG
- ▶ Each Wire is Rated 50V AC/DC at 3.5A (max.) Continuous, or 16A (max.) Pulse; Maximum Pulse Width is 400 msec with 10 Second Minimum Off Time Between Pulses
- ▶ 12" Minimum Wire Leads
- ▶ 5-year Warranty

ETW8 - MOLEX

Eight Wire Electric Thru-Wire with Molex Connectors

- ▶ Same Features as Above with Molex Connectors Installed on Wires Both Sides



Available on Models

HD1100
HD2400 (Handed)
HD2700



STANDARD LOCATIONS

HINGE LENGTH	TOP OF HINGE TO CENTERLINE
83"	40 1/2"
85"	42 1/2"
95"	52 1/2"
119"	76 1/2"

All sizes located 42 1/2" centerline from bottom of hinge

DRILL 3/4" HOLE IN FRAME AND DOOR TO ACCEPT WIRES FOR ETW8 & ETW12

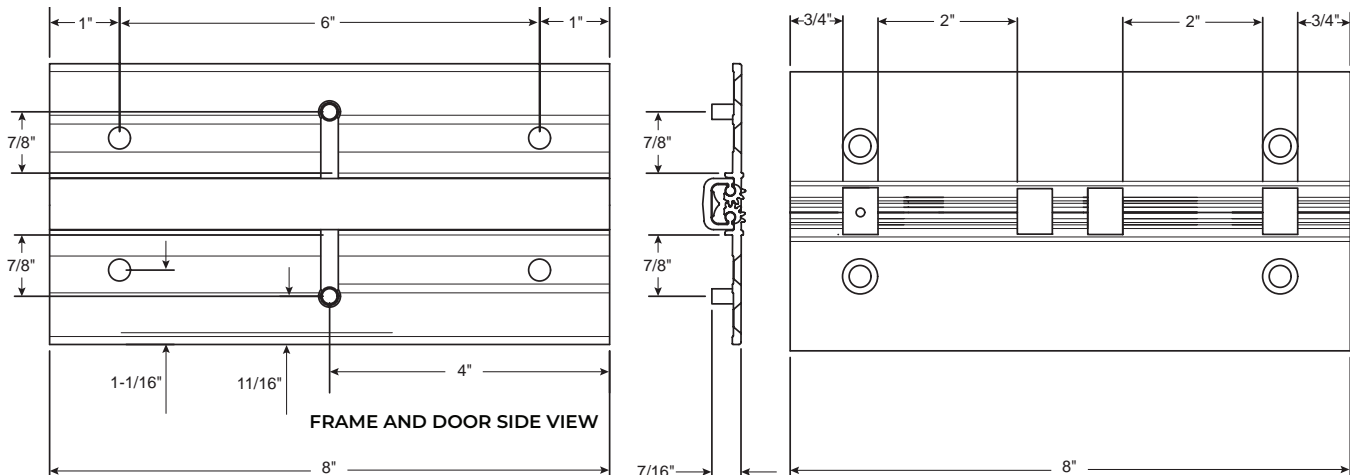

ELECTRIC THRU-WIRE

ETW12

Twelve Wire Electric Thru-Wire

Transfers Electric Power Through The Hinge To Power Certain Types Of Electronic Builders Hardware.

REMOVABLE ELECTRIC HINGE SECTION

- ▶ 12 Wires, 28 AWG
- ▶ Each Wire is Rated 50V AC/DC at 3.5A (max.) Continuous, or 16A (max.) Pulse; Maximum Pulse Width is 400 msec with 10 Second Minimum Off Time Between Pulses
- ▶ 12" Minimum Wire Leads
- ▶ 5-year Warranty

ETW12 - MOLEX

Twelve Wire Electric Thru-Wire with Molex Connectors

- ▶ Same Features as Above with Molex Connectors Installed on Wires Both Sides



ETW12-MOLEX Connector

Available on Models

- HD1100
- HD2400 (Handed)
- HD2700



STANDARD LOCATIONS

HINGE LENGTH	TOP OF HINGE TO CENTERLINE
83"	40 ½"
85"	42 ½"
95"	52 ½"
119"	76 ½"

All sizes located 42½" centerline from bottom of hinge

DRILL 3/4" HOLE IN FRAME AND DOOR TO ACCEPT WIRES FOR ETW8 & ETW12

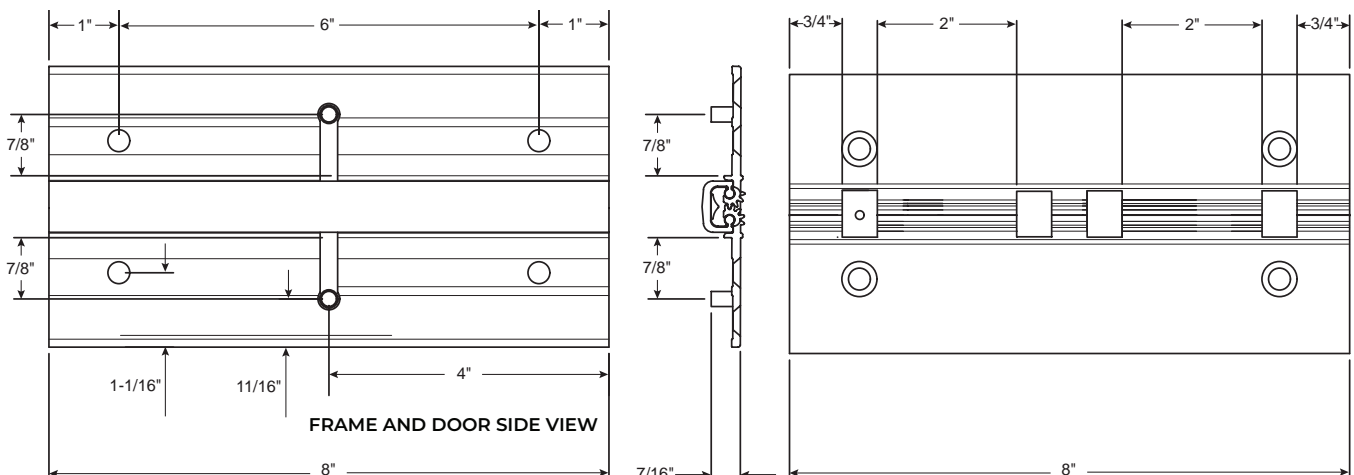

CONTINUOUS GEARED HINGE

ELECTRIC POWER TRANSFER (EPT) PREP

EPT PREP *(Option)*

Allows use of electric power transfer units required to power certain types of electronic builders hardware.

- Prep available for the following electric power transfer units
 - Von Duprin EPT-2, EPT-10, EPT-10C, PNT-1
 - Adams Rite 4612 (short version only)
 - Securitron EPT, EPT-SC, EL-EPT, EL-EPT-SC
 - Dorma ES105

Available on All Concealed and Half Surface Type Hinges

Non-Handed Models

HD1100 HD2700

Handed Models - Specify Door Hand

HD1400 HD1800 HD2400 HD4100
HD4200 HD5200 HD5300 HD5400

Standard Locations

HINGE LENGTH	TOP OF HINGE TO CENTERLINE OF PREP
83"	28 ⁷ / ₁₆ "
85"	30 ⁷ / ₁₆ "
95"	40 ¹ / ₂ "
119"	64 ³ / ₈ "



CONTINUOUS GEARED HINGE

ANTI-LIGATURE HOSPITAL TIP

TIPIT® LG

For Use in Hospitals, Correctional Facilities, Schools and Other Institutions.

Make rooms safer and meet legal requirements by retrofitting doors with the patented TIPIT® hospital tip. The tip deters patients or inmates from harming themselves by hanging objects from the hinge.

- Prevents objects from being attached to top of hinge (ligature-resistant)
- Made from durable, high-tech polymer
- Securely fastens to door frame header
- Works for retrofit or new applications
- Fits most other brands of geared continuous hinges
- Includes #10 Torx® SST security screws
- Color: Gray

TIPIT® hospital tip works with our geared continuous hinges to meet institutional requirements for preventing objects from being hung from the hinge.

Order the TIPIT® hospital tip with any new geared continuous hinge, or add this safety feature to most other brands of full surface, half surface, concealed or swing clear geared continuous hinges (new or retrofit applications).

ALHT (Option)

For Use in Hospitals, Behavioral Health, Prisons and Anywhere Anti-Ligature Protection is Required

Available on concealed model hinges only

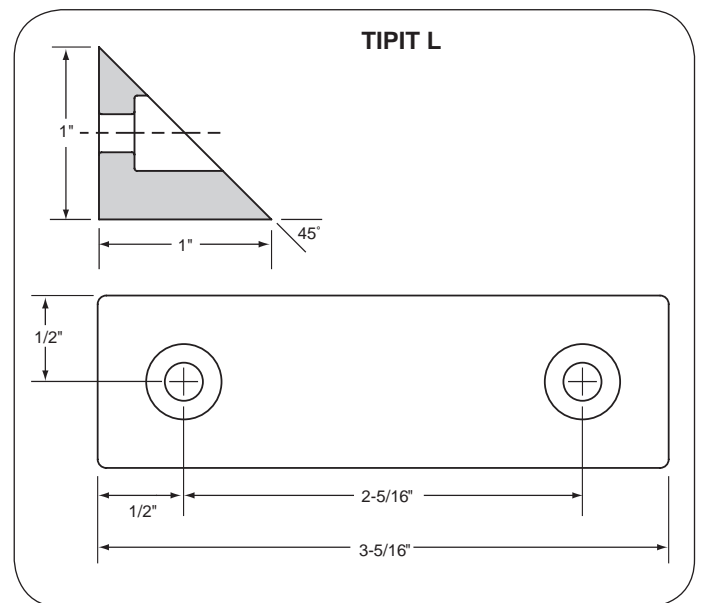

STAINLESS STEEL CONTINUOUS HINGE

CONCEALED

UP TO 1/8" INSET, FOR 1 3/4" DOORS

SS300

Stainless steel continuous hinges run the full height of the door, evenly distributing the weight of the door along the full height of the frame. Ideal for high-frequency and heavy-weight doors in new construction and retrofit applications.

- Heavy-duty Type 304, 14-gauge stainless steel
- Pin and barrel design
- Stainless steel hinge pins
- Medical type self-lubricating flanged bearings between each 2" knuckle provide dust-free quiet and smooth operation
- For doors weighing up to 600 lbs.
- 25-year warranty
- #10 x 1/2" TEK screws for metal doors and frames
- #10 x 1" wood screws for wood doors
- US32D (630) brushed finish
- Standard lengths: 83", 85", 95", 119"

FULL MORTISE (EDGE MOUNT)

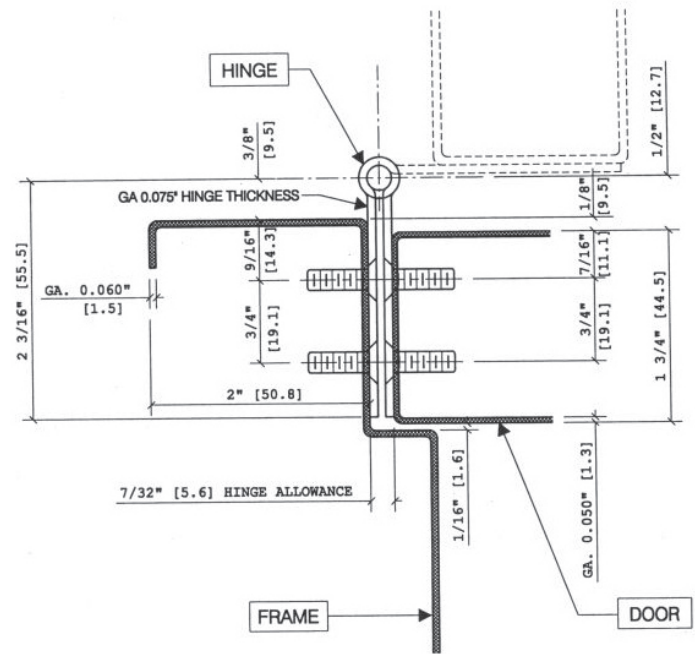

Available Options

- Torx Security TEK Screws
- Cut to Net Length
- Anti-Ligature Welded Hospital Tip - Specify "ALHT"
- Dutch Door Prep - Specify Door Handing, Bottom Door Leaf Length, and Clearance Between Leafs
- Electric Thru-Wire ETW8 - See page CH26
- Electric Power Transfer Prep - See page CH26
- US32 (629) Polished Finish
- Welded Tips for Non-Rising Pins



Fire-rated 3 hours on hollow metal doors and 90-minute on wood doors. Maximum size 4'0" x 10'0"



ANSI/BHMA Certified to A156.26 American National Standard for Continuous Hinges:
Grade 1 - 150 lb. Door



STAINLESS STEEL CONTINUOUS HINGE

CONCEALED

FULL WRAP EDGE GUARD, FOR 1 3/4" DOORS

SS305

Stainless steel continuous hinges run the full height of the door, evenly distributing the weight of the door along the full height of the frame. Ideal for high-frequency and heavy-weight doors in new construction and retrofit applications.

- ▶ Heavy-duty Type 304, 14-gauge stainless steel
- ▶ Pin and barrel design
- ▶ Stainless steel hinge pins
- ▶ Medical type self-lubricating flanged bearings between each 2" knuckle provide dust-free quiet and smooth operation
- ▶ For doors weighing up to 600 lbs.
- ▶ 25-year warranty
- ▶ #10 x 1/2" TEK screws for metal doors and frames
- ▶ #10 x 1" wood screws for wood doors
- ▶ US32D (630) brushed finish
- ▶ Standard lengths: 83", 85", 95", 119"

Available Options

- ▶ Torx Security TEK Screws
- ▶ Cut to Net Length - Specify Door Handing
- ▶ Anti-Ligature Welded Hospital Tip - Specify "ALHT"
- ▶ Dutch Door Prep - Specify Door Handing, Bottom Door Leaf Length, and Clearance Between Leafs
- ▶ Electric Thru-Wire ETW8 - See page CH26
- ▶ Electric Power Transfer Prep - See page CH26
- ▶ US32 (629) Polished Finish
- ▶ Welded Tips for Non-Rising Pins



Fire-rated 3 hours on hollow metal doors and 90-minute on wood doors. Maximum size 4'0" x 10'0"



ANSI/BHMA Certified to A156.26 American National Standard for Continuous Hinges:
Grade 1 - 150 lb. Door

FULL WRAP EDGE GUARD (EDGE MOUNT)

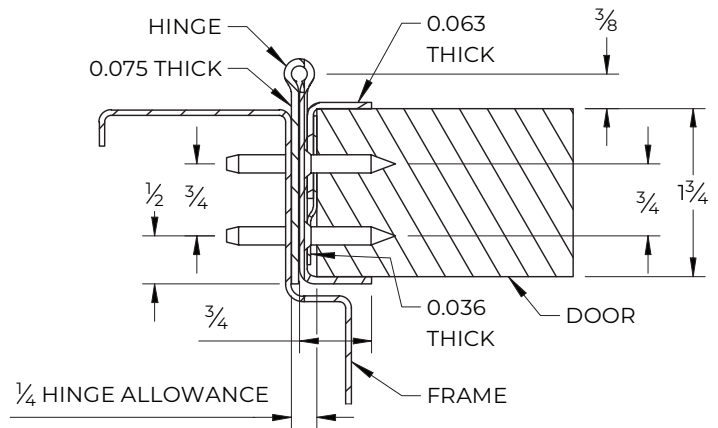

STAINLESS STEEL CONTINUOUS HINGE

CONCEALED

HALF WRAP EDGE GUARD, FOR 1 3/4" DOORS

SS315

Stainless steel continuous hinges run the full height of the door, evenly distributing the weight of the door along the full height of the frame. Ideal for high-frequency and heavy-weight doors in new construction and retrofit applications.

- Heavy-duty Type 304, 14-gauge stainless steel
- Pin and barrel design
- Stainless steel hinge pins
- Medical type self-lubricating flanged bearings between each 2" knuckle provide dust-free quiet and smooth operation
- For doors weighing up to 600 lbs.
- 25-year warranty
- #10 x 1/2" TEK screws for metal doors and frames
- #10 x 1" wood screws for wood doors
- US32D (630) brushed finish
- Standard lengths: 83", 85", 95", 119"

HALF WRAP EDGE GUARD (EDGE MOUNT)

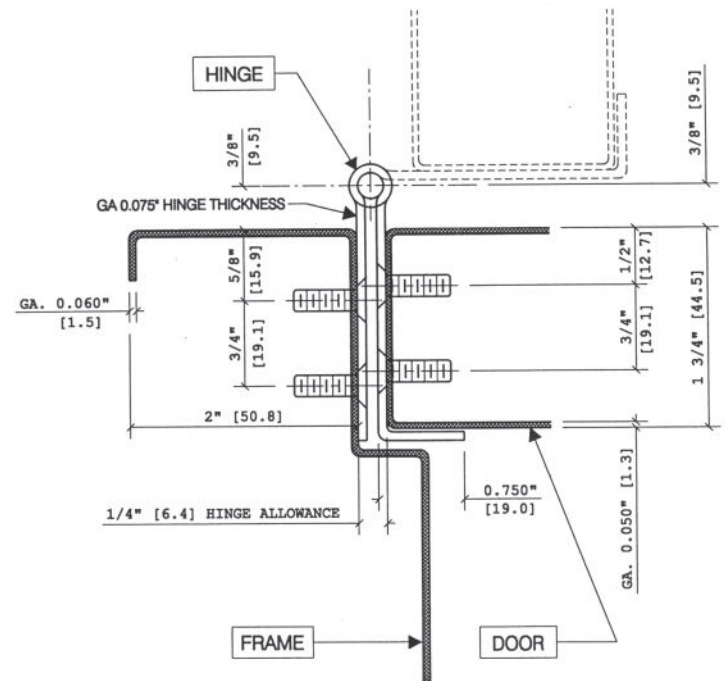

Available Options

- Torx Security TEK Screws
- Cut to Net Length - Specify Door Handing
- Anti-Ligature Welded Hospital Tip - Specify "ALHT"
- Dutch Door Prep - Specify Door Handing, Bottom Door Leaf Length, and Clearance Between Leafs
- Electric Thru-Wire ETW8 - See page CH26
- Electric Power Transfer Prep - See page CH26
- US32 (629) Polished Finish
- Welded Tips for Non-Rising Pins



Fire-rated 3 hours on hollow metal doors and 90-minute on wood doors. Maximum size 4'0" x 10'0"



ANSI/BHMA Certified to A156.26 American National Standard for Continuous Hinges:
Grade 1 - 150 lb. Door



STAINLESS STEEL CONTINUOUS HINGE

SWING CLEAR

WITH HALF WRAP EDGE GUARD, FOR 1 3/4" DOORS

SS311

Stainless steel continuous hinges run the full height of the door, evenly distributing the weight of the door along the full height of the frame. Ideal for high-frequency and heavy-weight doors in new construction and retrofit applications.

- ▶ Heavy-duty Type 304, 14-gauge stainless steel
- ▶ Pin and barrel design
- ▶ Stainless steel hinge pins
- ▶ Medical type self-lubricating flanged bearings between each 2" knuckle provide dust-free quiet and smooth operation
- ▶ For doors weighing up to 600 lbs.
- ▶ 25-year warranty
- ▶ #10 x 1/2" TEK screws for metal doors and frames
- ▶ #10 x 1" wood screws for wood doors
- ▶ US32D (630) brushed finish
- ▶ Standard lengths: 83", 85", 95", 119"

Available Options

- ▶ Torx Security TEK Screws
- ▶ Cut to Net Length - Specify Door Handing
- ▶ Dutch Door Prep - Specify Door Handing, Bottom Door Leaf Length, and Clearance Between Leafs
- ▶ US32 (629) Polished Finish
- ▶ Welded Tips for Non-Rising Pins

SWING CLEAR HINGE GUARD

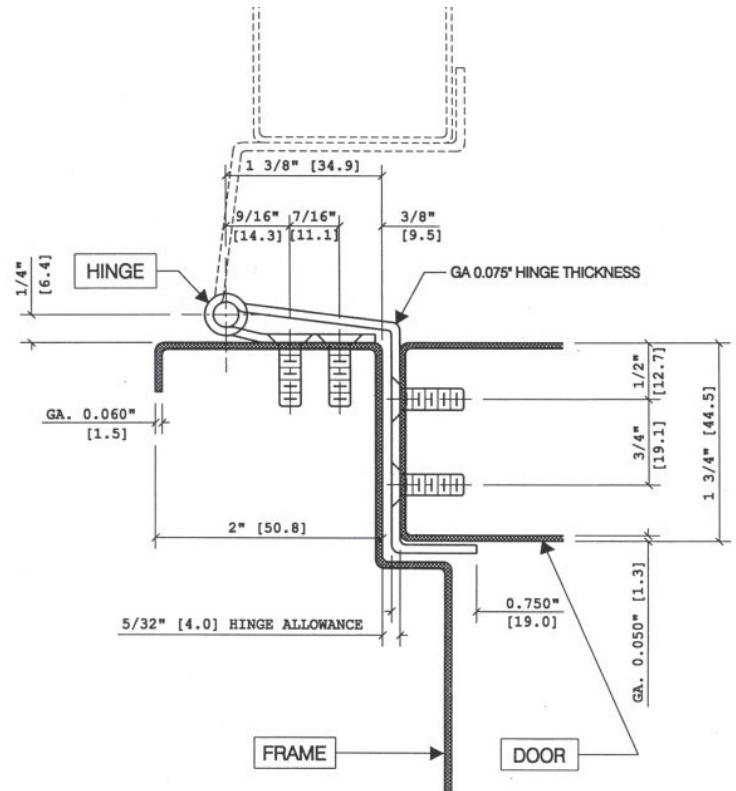

Fire-rated 3 hours on hollow metal doors and 90-minute on wood doors. Maximum size 4'0" x 10'0"



ANSI/BHMA Certified to A156.26 American National Standard for Continuous Hinges:
Grade 1 - 150 lb. Door

STAINLESS STEEL CONTINUOUS HINGE

FULL SURFACE

SS302

Stainless steel continuous hinges run the full height of the door, evenly distributing the weight of the door along the full height of the frame. Ideal for high-frequency and heavy-weight doors in new construction and retrofit applications.

- Heavy-duty Type 304, 14-gauge stainless steel
- Pin and barrel design
- Stainless steel hinge pins
- Medical type self-lubricating flanged bearings between each 2" knuckle provide dust-free quiet and smooth operation
- For doors weighing up to 600 lbs.
- 25-year warranty
- # $\frac{1}{4}$ -20 x $\frac{3}{4}$ " TEK screws for metal doors and frames
- US32D (630) brushed finish
- Standard lengths: 83", 85", 95", 119"

Available Options

- Torx Security TEK Screws
- Thru-Bolts for 1 $\frac{3}{4}$ " doors - Specify "SSH-TB"
- Cut to Net Length - Specify Door Handing
- Dutch Door Prep - Specify Door Handing, Bottom Door Leaf Length, and Clearance Between Leafs
- US32 (629) Polished Finish
- Welded Tips for Non-Rising Pins



Fire-rated 3 hours on hollow metal doors and 90-minute on wood doors. Maximum size 4'0" x 10'0"



ANSI/BHMA Certified to A156.26 American National Standard for Continuous Hinges:
Grade 1 - 150 lb. Door

FULL SURFACE (FLUSH)

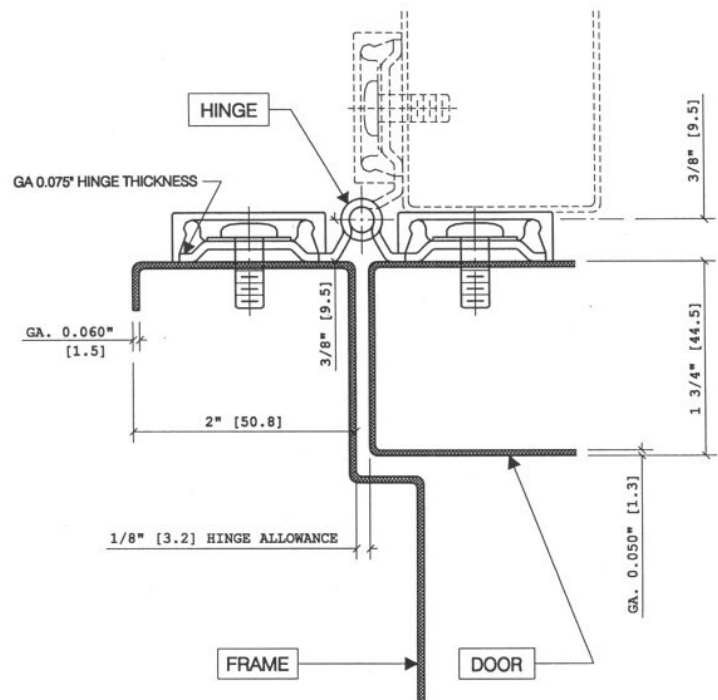

STAINLESS STEEL CONTINUOUS HINGE

HALF MORTISE

FOR 1 3/4" DOORS

SS304

Stainless steel continuous hinges run the full height of the door, evenly distributing the weight of the door along the full height of the frame. Ideal for high-frequency and heavy-weight doors in new construction and retrofit applications.

- Heavy-duty Type 304, 14-gauge stainless steel
- Pin and barrel design
- Stainless steel hinge pins
- Medical type self-lubricating flanged bearings between each 2" knuckle provide dust-free quiet and smooth operation
- For doors weighing up to 600 lbs.
- 25-year warranty
- #1/4"-20 x 3/4" TEK screws for metal frames
- #10 x 1/2" TEK screws for metal doors
- #10 x 1" wood screws for wood doors
- US32D (630) brushed finish
- Standard lengths: 83", 85", 95", 119"

HALF MORTISE (EDGE MOUNT)

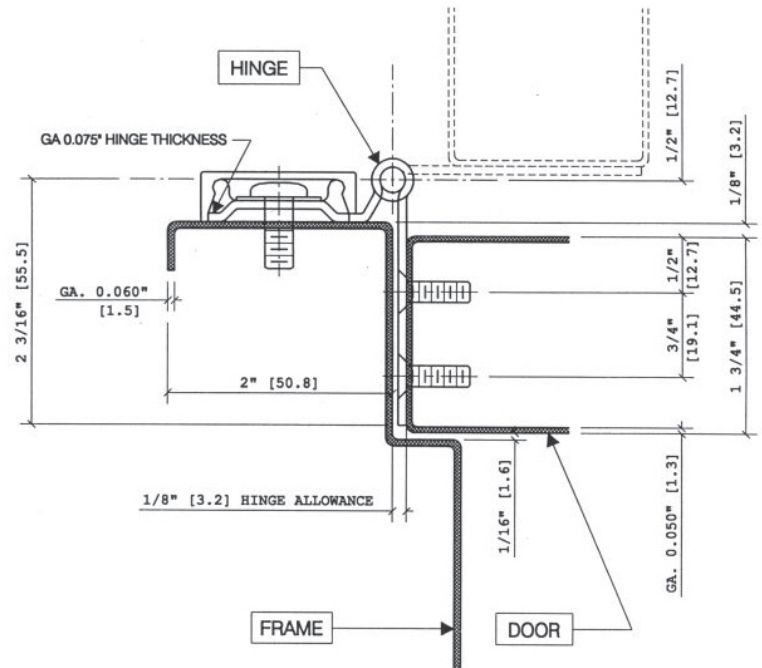

Available Options

- Torx Security TEK Screws
- Cut to Net Length - Specify Door Handing
- Dutch Door Prep - Specify Door Handing, Bottom Door Leaf Length, and Clearance Between Leafs
- Electric Power Transfer Prep - See page CH26
- US32 (629) Polished Finish
- Welded Tips for Non-Rising Pins



Fire-rated 3 hours on hollow metal doors and 90-minute on wood doors. Maximum size 4'0" x 10'0"



ANSI/BHMA Certified to A156.26 American National Standard for Continuous Hinges:
Grade 1 - 150 lb. Door



STAINLESS STEEL CONTINUOUS HINGE

HALF MORTISE

WITH HALF WRAP EDGE GUARD, FOR 1 3/4" DOORS

SS306

Stainless steel continuous hinges run the full height of the door, evenly distributing the weight of the door along the full height of the frame. Ideal for high-frequency and heavy-weight doors in new construction and retrofit applications.

- Heavy-duty Type 304, 14-gauge stainless steel
- Pin and barrel design
- Stainless steel hinge pins
- Medical type self-lubricating flanged bearings between each 2" knuckle provide dust-free quiet and smooth operation
- For doors weighing up to 600 lbs.
- 25-year warranty
- #3/4-20 x 3/4" TEK screws for metal frames
- #10 x 1/2" TEK screws for metal doors
- #10 x 1" wood screws for wood doors
- US32D (630) brushed finish
- Standard lengths: 83", 85", 95", 119"

Available Options

- Torx Security TEK Screws
- Cut to Net Length - Specify Door Handing
- Dutch Door Prep - Specify Door Handing, Bottom Door Leaf Length, and Clearance Between Leafs
- Electric Power Transfer Prep - See page CH26
- US32 (629) Polished Finish
- Welded Tips for Non-Rising Pins



Fire-rated 3 hours on hollow metal doors and 90-minute on wood doors. Maximum size 4'0" x 10'0"

HALF MORTISE/GUARD (EDGE MOUNT)

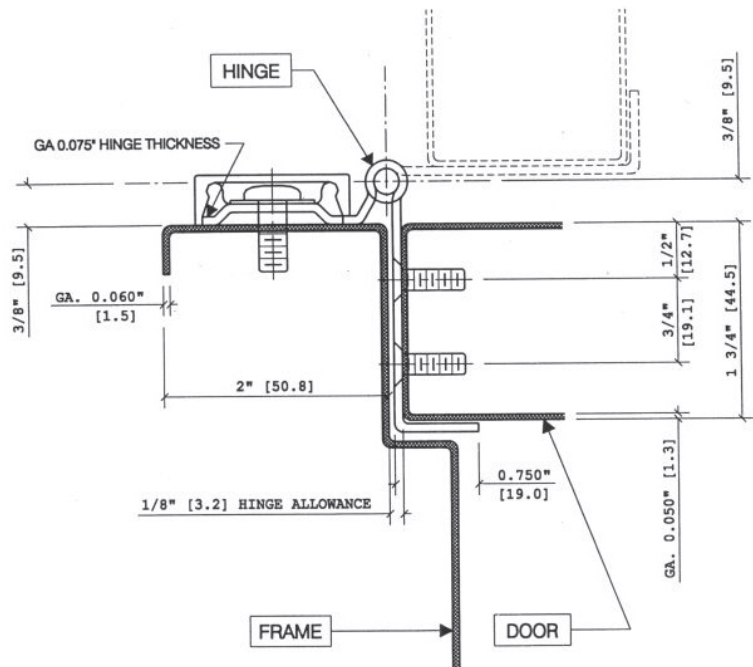

STAINLESS STEEL CONTINUOUS HINGE

ELECTRIC

ELECTRIC THRU-WIRE

ETW8

Transfers electric power through the hinge to power certain types of electronic builders hardware.

Removable Electric Hinge Section

- 8 wires, 26 AWG
- Each wire is rated 24V AC/DC at 0.5A (max.) continuous or pulse
- 12" wire leads
- 5-year warranty

Available on Models

SS300
SS305 (Handed)
SS315 (Handed)

Standard Location, All Sizes: 39 5/8" Centerline from Bottom of Hinge

ELECTRIC POWER TRANSFER PREP

EPT PREP

Allows use of electric power transfer units required to power certain types of electronic builders hardware.

- Prep available for the following electric power transfer units
 - Von Duprin EPT-2, EPT-10, EPT-10C, PNT-1
 - Adams Rite 4612 (short version only)
 - Securitron EPT, EPT-SC, EL-EPT, EL-EPT-SC
 - Dorma ES105

Available on All Concealed and Half Surface Type Hinges

Non-Handed Models

SS300

Handed Models - Specify Door Hand

SS304, SS305, SS306, SS315

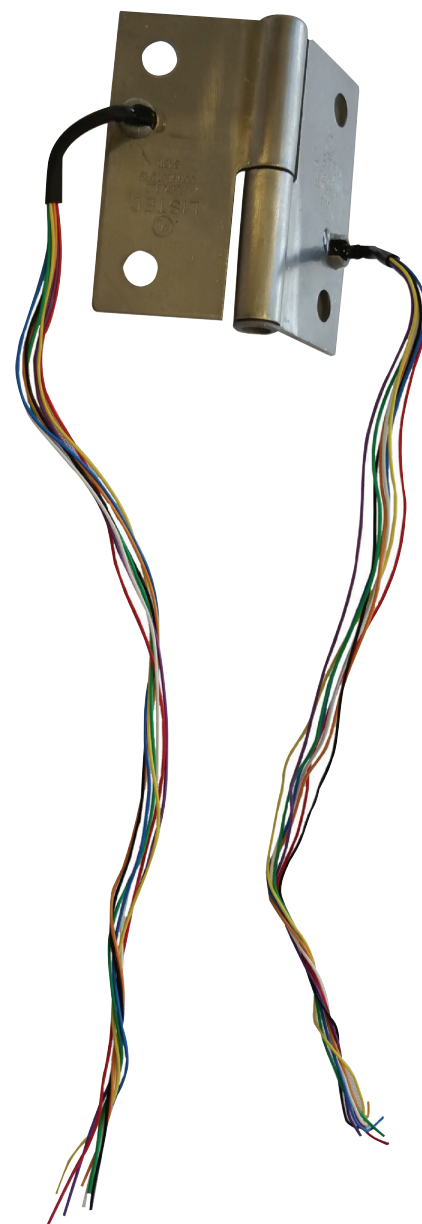

Standard Locations

HINGE LENGTH	TOP OF HINGE TO CENTERLINE OF PREP
83"	28 7/16"
85"	30 7/16"
95"	40 1/2"
119"	64 3/8"



For the most up-to-date
Hinges Catalog
scan the QR code
or visit ngp.com.



ngp.com
1-800-NGP-RUSH

FAX: (800) 255-7874
QUOTES: quotes@ngp.com
ORDERS: orders@ngp.com

NGP MEMPHIS
4985 East Raines Road
Memphis, TN 38118

CARSON CITY
3689 Arrowhead Drive
Carson City, NV 89706