



EXOLON MULTI FOR GREENHOUSES

EXCELLENCE IN POLYCARBONATE SHEETS

EXTRUSION EXCELLENCE



- We are leader in polycarbonate mono and multi sheets
 - We develop cutting edge technologies
 - We believe in the strength of partnerships
- We are committed to grow together



EXOLON GROUP



Exolon Group NV

Belgium (Tielt)

Mono production plant



Exolon Group GmbH

Germany
Admin HQ

Exolon Group SpA

Italy (Nera Montoro)
Multi production plant



>50 kt/y of capacity installed

Exolon Group is part of

serafin

UNTERNEHMENSGRUPPE

Verantwortung aus Tradition

MULTIWALL: A COMPLETE PORTFOLIO

THICKNESS									
4mm	6mm	8mm	10mm	16mm	20mm	25mm	32mm	40mm	50mm

GENERAL PURPOSE

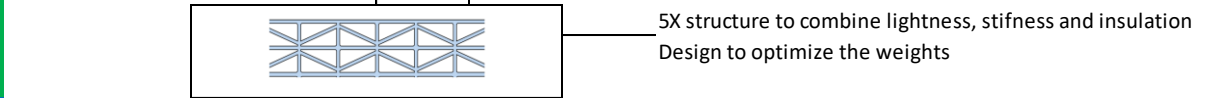
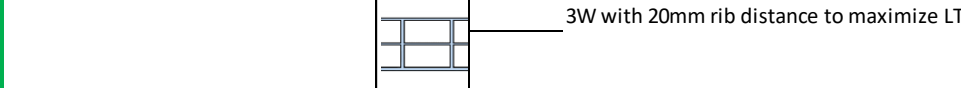
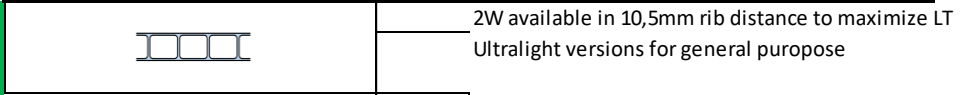

INDUSTRIAL

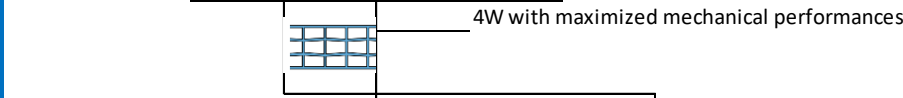

ENERGY SAVING

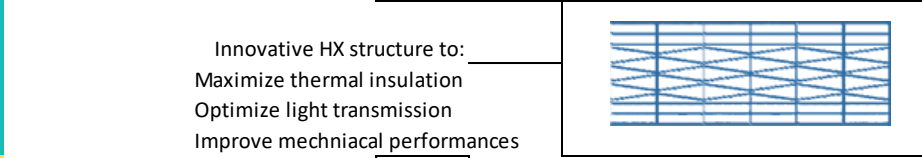

SPECIALS

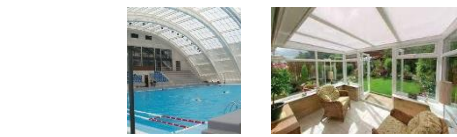
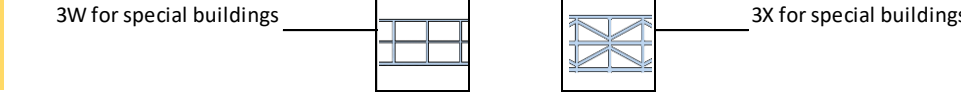
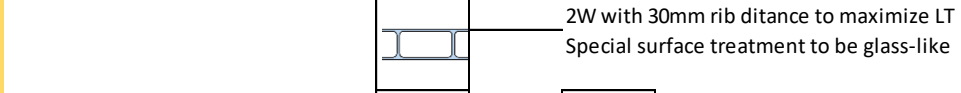

CONTENTS



- Greenhouse basics
- Used materials – advantages of polycarbonate
- Exolon solutions for greenhouses
- Special features
 - » Light diffusion
 - » IR reflection
 - » NO Drop
 - » Esthetic

GREENHOUSES: THE BASICS

- Uniform and reliable plant growth
- Safer and easier work conditions
- Minimize impact on the environment



Simple Tech

- Inexpensive
- Tunnel shape (plastic film)
- No control/automatization
- Pest and disease control via chemicals



High Tech

- Big structures (plastic or glass sheets)
- Automated environmental control
- High yield and low impact
- Integrated Pest Management



CROPS IN GREENHOUSES

- Vegetables (mainly: tomatoes, cucumbers, pepper...)
- Fruits (citrus, grape, melon, fig, apricot, strawberries...)
- Cut flowers (roses, chrysanthemums...)
- Edible flowers
- Potted and ornamental plants (orchids, poinsettias...)
- Tobacco
- Mushrooms
- Seedlings – breeding
- Agro forestry
- Botanic gardens
- Fish farming



HIGH TECH: THE FUTURE OF GREENHOUSES

- Improvement of efficiency of crop growth (speed and production capacity per m²)
- Reduce the use of soil, water and energy
- Possibility to cultivate in extreme conditions
- Recreate best conditions for crop growth allowing local productions
- Automatizations to minimize the human efforts



VARIOUS DESIGNS

Tunnel



- Simplest
- Low air volume → Low control on the environment
- Material: plastic film (usually PE)

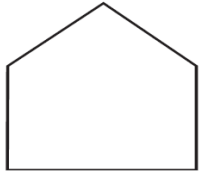

Gable and Raised Dome

- Good natural ventilation
- Good light transmission (curved roofs guarantee the best performance along the year)
- Material: plastic or glass sheets

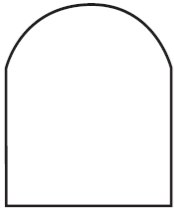

MATERIALS: PLASTIC FILM

- Polymers: PE, FEP, LDPE, PVC, PU, PVF, THV, EVA, ETFE
- Thickness: 15 – 200 µm

Advantages

- Simplest and cheapest
- Various types for special properties
- High light transmission
- Good diffusion
- Easy transport and installation
- Extensive high span

Disadvantages

- Short lifetime
- Intensive replacement labor
- IR transparent → heat build up
- UV transparent
- Deformation due to heat
- No insulation
- Limited control on the internal environment
- Limited storm resistance
- Not indicated for extreme weather (desert, snow...)
- Electrostatic charge

MATERIALS: GLASS SHEETS

- Types: float, cast, laminated, low iron, low ferric oxide
- Thickness: 4mm

Advantages

- Long life
- High light transmission
- Good condensation properties
- Non inflammable
- Chemical resistant
- Low thermal expansion

Disadvantages

- Expensive
- Heavy and heavy structures
- Low span structures → direct shadows
- Not easily workable (no bending)
- UV transparent
- Fragile → risk of hail
- Limited insulation

MATERIALS PMMA SHEETS

- Types: multiwall
- Thickness: 6mm – 10mm

Advantages

- Longer life than film
- High light transmission
- No yellowing
- Good thermal insulation
- Good no drop (surface and in chambers)
- Good load characteristics

Disadvantages

- Cost per m²
- UV transparent
- Fragile → risk of hail
- Not easily workable (limited bending radius)
- Heavy and expensive construction profiles
- Chemical resistance
- Bad fire reaction

POLYCARBONATE IN GREENHOUSES



- Types: multiwall
- Thickness: 4mm – 16mm

Advantages

- Longer life than film
- Unbreakable → ideal also for extreme wear
- Good fire reaction
- Easy to work and bend
- Light and good mechanical properties → lighter and cheaper structures
- Extreme thermal insulation → energy saving and control on the environment
- UV protection (safer environment for people and various effects on growth)

Disadvantages

- Requires proper UV protection
- Lower light transmittance, but compensate by diffusion, insulation and curved roof
- Thermal expansion
- Possible moisture or dirt in chambers

EXOLON MULTI FOR GREENHOUSES



Product	Thickness (mm)	Pitch (mm)	Area weight (kg/m ²)	Available colours	Light transmittance for clear (%)	Ug vertical (W/m ² K)	Special types
Exolon Multi UV 2/4-8	4	8	0,8	Clear, Opal, White, Bronze	82	4,0	
Exolon Multi UV 2/6-8	6	8	1,3	Clear, Opal, White, Bronze, Green, Blue	82	3,5	2UV
Exolon Multi UV 2/8-10,5	8	10,5	1,5	Clear, Opal, White, Bronze, Green, Blue	81	3,3	2UV, IQ-Relax, No Drop
Exolon Multi UV 2/10-10,5	10	10,5	1,7	Clear, Opal, White, Bronze, Green, Blue	80	3,0	2UV, IQ-Relax, No Drop
Exolon Multi UV 2/16-30	16	30	2,8-3,6	Clear, Opal	77	2,8	2UV, vitalized
High pitch to maximize the light transmission							
Exolon Multi UV 2/4-8 UL	4	8	0,65	Clear, Opal, Bronze	82	4,0	
Exolon Multi UV 2/6-8 UL	6	8	1,05	Clear, Opal, Bronze	82	3,5	
Exolon Multi UV 2/8-8 UL	8	8	1,2	Clear, Opal, Bronze	81	3,3	
Exolon Multi UV 2/10-8 UL	10	8	1,3	Clear, Opal, Bronze	80	3,0	

Optimized area weight

5X TO BOOST INSULATION

Product	Thickness (mm)	Pitch (mm)	Area weight (kg/m ²)	Available colours	Light transmittance for clear (%)	Ug vertical (W/m ² K)	Special types
Exolon Multi UV 5X/8-25	8	25	1,4	Clear, Opal, White	71	2,8	2UV
Exolon Multi UV 5X/10-25	10	25	1,5	Clear, Opal, White	68	2,5	2UV
Exolon Multi UV 5X/16-25	16	25	2,25 – 2,4	Clear, Opal, White	64	2,0	2UV, IQ-Relax, No Drop
Exolon Multi UV 5X/20-25	20	25	2,8	Clear, Opal, White	60	1,8	2UV, IQ-Relax, No Drop

High thermal insulation for greenhouses walls

EXOLON MULTI UV 5X/8-25



Exolon's High Insulating sheet for Greenhouses

- Designed to combine insulation, lightness, stiffness
- High insulation for 8mm: $U_g=2,8 \text{ W/m}^2\text{K}$
- X structure to increase the stiffness
- Ideal for greenhouses walls

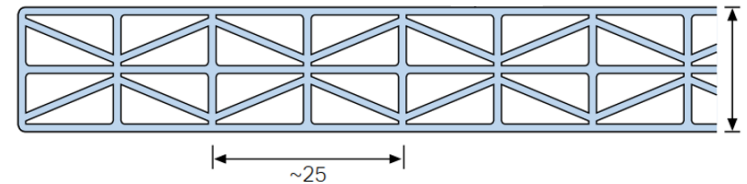
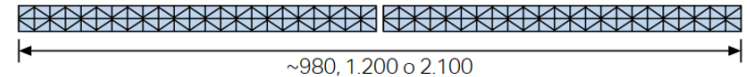

EXOLON MULTI UV 5X8 VS STANDARD TWINWALL 8MM

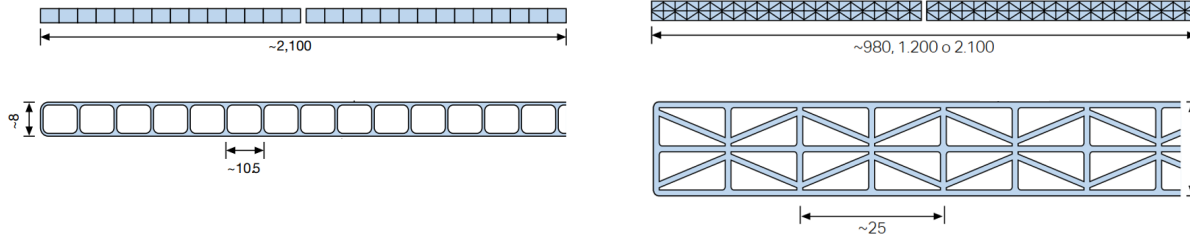

Ug from 3,3 to 2,8 W/m²K

**15% Improved
thermal insulation**

Better insulation avoids Hot&Cold air mixing (“short circuiting”)

- Reduces the energy consumptions.
- Reduces the server failure rate.
- Reduces air flow rate requirements.

EXOLON MONO SHEETS FOR GREENHOUSES



Product	Thickness (mm)	Area weight (g/cm ³)	Light transmittance for clear (%)	Ug vertical (W/m ² K)
Exolon UV 2mm	2	1,2	88	5,6
Exolon UV 3mm	3	1,2	87	5,5
Exolon UV 4mm	4	1,2	87	5,4
Exolon UV 5mm	5	1,2	86	5,2
Exolon UV 6mm	6	1,2	85	5,1

POLYCARBONATE IN GREENHOUSES: ADVANTAGES



Longer life than film

- Exolon UV has a standard warranty of 10 years
- Customized warranties are available (e.g. 20 years)
- Film must be changed every 3 years → high labor costs; wastes
- CE marked sheets according EN 16153



Example

POLYCARBONATE IN GREENHOUSES: ADVANTAGES

Unbreakable

- Exolon PC is about 100 times more resistant than glass
- Exolon PC is about 25 times more resistant than PMMA
- High resistance to difficult and extreme weather conditions:

Storms

High winds (e.g. from the sea like in South Europe)

Snow

Desert

ASTM D3763 (3,175mm sheets)

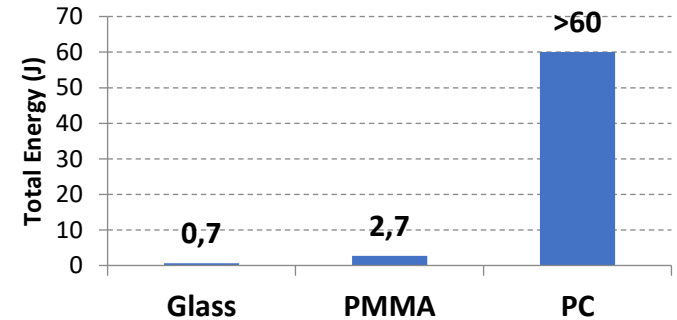

POLYCARBONATE IN GREENHOUSES: ADVANTAGES

Good fire reaction

- Classified B-s1 d0 according EN13501-1
- PC requires more O₂ than in air to burn → self-extinguishing
- PMMA requires less O₂ than in air to burn → flames propagate
- In case of fire Exolon PC do not pose any more toxicity risk than natural products according to DIN 53436



POLYCARBONATE IN GREENHOUSES: ADVANTAGES



Easy to work and bend

- Exolon PC can be easily worked
- Simple profiles available
- Easily cut with fine toothed handsaws, circular saws, band saws or other types of saws.
- Cold bending allows curved structures
- Curved roofing maximize the light in during the whole year
(due to the sun path in the sky during the day and the seasons)

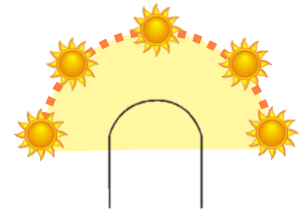
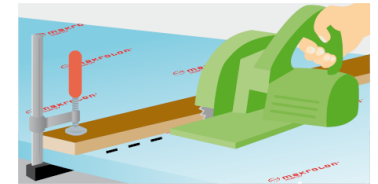
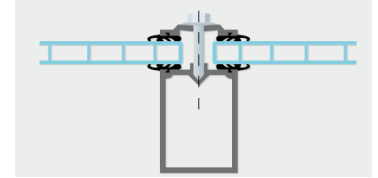

POLYCARBONATE IN GREENHOUSES: ADVANTAGES

Mechanical properties

- Exolon Multi have optimized area weight
- High load resistance:
 - simpler structures and high span
 - lower direct shadow
 - lower costs in structures

Frames, ground preparations and labor are about
80% of the structure costs

Example: Exolon Multi UV 2/10-10,5

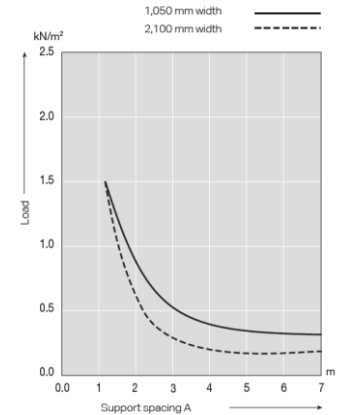

ADVANTAGES OF EXOLON SHEETS

Thermal insulation

Temperature plays a very important role in plant growth:

Temperature control si a key point

biomass growth has an optimal temperature (depends on the plant, the light, the day cycle...)

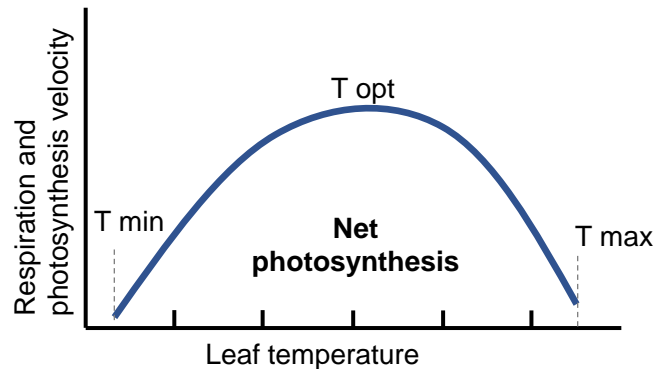

→ if T_{si} too low: not enough photosynthesis

→ if T_{si} too high: too much respiration

ADVANTAGES OF EXOLON SHEETS



Thermal insulation

Keeping the right temperature during the night/day is important to

Temperature control si a key point

- assure a proper and optimized growth
- keep a correct level of relative humidity
- minimize fungi proliferations

ADVANTAGES OF EXOLON SHEETS

Thermal insulation

Temperature control si performed via:

Ventilation → but removes the CO₂ and reduces its fertilization effect

Heating/Cooling → energy consumptions

Temperature control si a key point



Thermal insulation improves the growth and reduces consumptions

ADVANTAGES OF EXOLON SHEETS

Thermal insulation

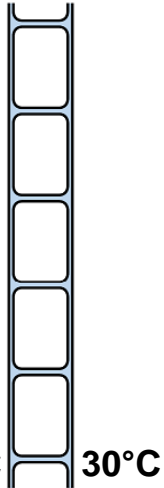

Example: Exolon Multi UV 2W8-10,5

weight: 1,5 kg/m²

U_g: 3,3 W/m²K

$$Q = U_g \cdot A \cdot \Delta T = 3,3 \text{ W/m}^2\text{°C} \cdot 1 \text{ m}^2 \cdot 10 \text{ °C} = 33 \text{ W}$$

4mm glass weights 11,5 kg/m² and has U_g of 6,7 W/m²K !

$$Q_{\text{glass}} = U_g \cdot A \cdot \Delta T = 6,7 \text{ W/m}^2\text{°C} \cdot 1 \text{ m}^2 \cdot 10 \text{ °C} = 67 \text{ W} \rightarrow \text{TWICE!}$$

Using 2 glass sheets with 8mm of air in between, the weight is 23 kg/m² (**15 times!**) the total thickness is 16mm (**2 times!**), the U_g becomes 3,8 and the heat exchanged remains **15% more!**

ADVANTAGES OF EXOLON SHEETS

Thermal insulation: a real case example

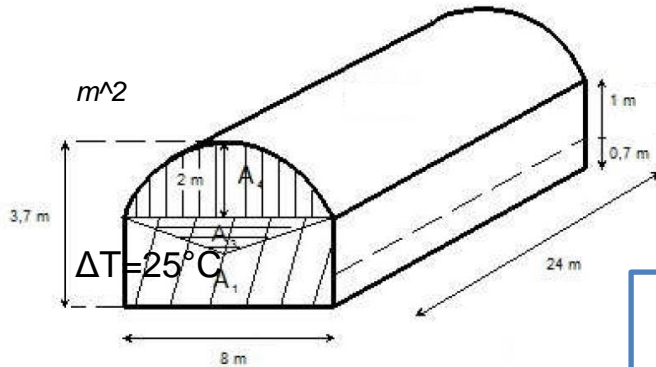

A_c = area of the covering = 353,76

A_g = area for cultivation = 192 m^2

T_i = 20°C

T_e = -5°C

→

$$\boxed{\text{Heat to provide } Q} = \boxed{\text{Heat loss through the covering}} + \boxed{\text{Heat loss due to air infiltrations}} - \boxed{\text{Heat given by solar radiation}}$$

Usually negligible because much lower than the losses trough the covering

We set to 0 to focus during the night and the early morning because during the day there si no need to heat up since the solar radiation si more than enough

ADVANTAGES OF EXOLON SHEETS

Thermal insulation: a real case example

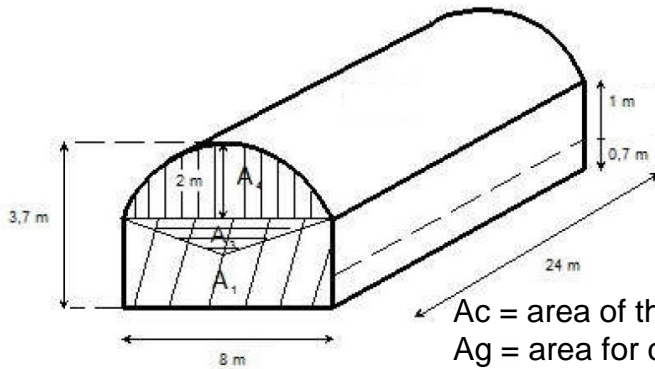

$A_c = \text{area of the covering} = 353,76 \text{ m}^2$
 $A_g = \text{area for cultivation} = 192 \text{ m}^2$
 $T_i = 20^\circ\text{C}$ $T_e = -5^\circ\text{C}$ $\rightarrow \Delta T = 25^\circ\text{C}$

$$\boxed{\text{Heat to provide } Q} = \boxed{\text{Heat loss through the covering}}$$

$$Q = 353,76 \cdot U \cdot 25$$

$$4\text{mm glass} : 59244,8 \text{ W}$$

$$2\text{W8 PC} : 29180,3 \text{ W}$$

POWER SAVED = 30064,5 W \rightarrow 156,6 W for each m^2 cultivated

ADVANTAGES OF EXOLON SHEETS

Thermal insulation: a real case example

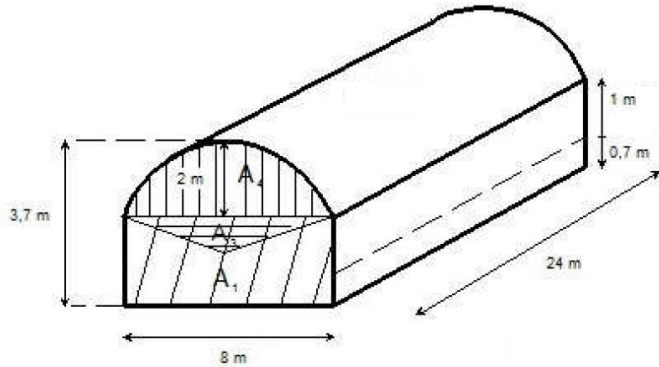

2W8 PC vs 4mm Glass **saves 156,6 W/m² cultivated**

Hot water requirements:

4mm glass : 1415 kg/s

2W8 PC : 697 kg/s

→ about **50% reduction** of hot water flow rate

ADVANTAGES OF EXOLON SHEETS



Thermal insulation: a real case example

<i>Data per m² cultivated</i>	POWER CONSUMPTION (W)	HOT WATER REQUIREMENT (kg/s)	CO2 PRODUCTION (kg/y)
4mm glass	309	1415	731
2W 8mm	152	697	360
EXOLON MULTI UV 5X8-25	129	591	306

A standard polycarbonate 2W8 reduces the impact of 51% versus a simple glass.

The more insulating EXOLON MULTI UV 5X8-25 further reduce it by another 15%

IMPORTANCE OF LIGHT

Light is fundamental for the photosynthesis and growth

Plants use only a part of the solar radiation, called PAR

PAR = Photosynthetically Active Radiation

PAR is a fraction of the visible light and designates the spectral range from 400 to 700 nm

(visible light has a spectral range from 380 to 740 nm)

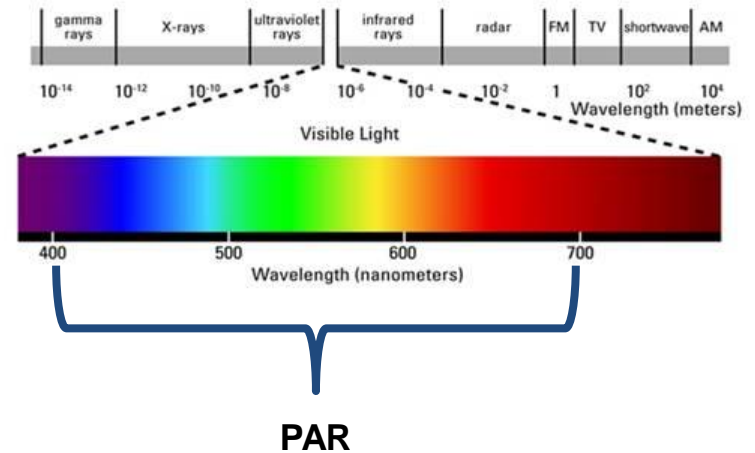

POLYCARBONATE IN GREENHOUSES: ADVANTAGES

UV protection

Polycarbonate absorbs the UV light

→ light that enters the greenhouse has not UV (both UV-A and UV-B)

- Improvements in plant growth

- Protection against insects and fungi minimizing the use of pesticides → integrated pest management (IPM)

- Safer environment for workers

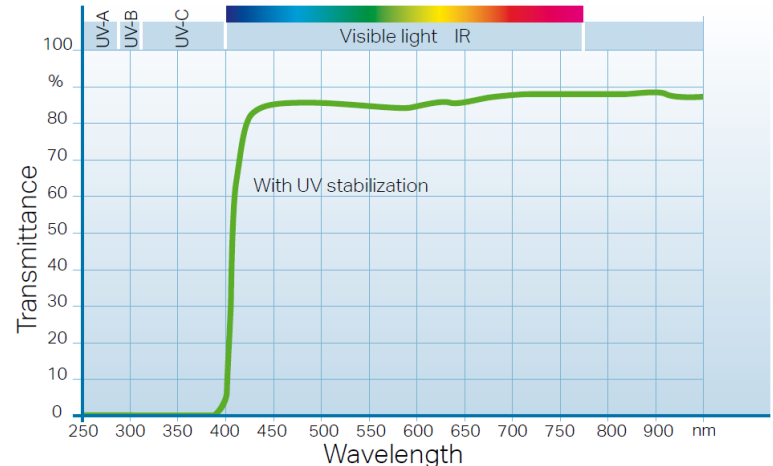

Solid sheet - Transmittance as a function of wavelength - Makrolon® clear transparent

ADVANTAGES OF EXOLON SHEETS



UV protection: improvements in plant growth

- Kittas et al. (2006) found that eggplants grown in the greenhouse with 0% transmission to UV light were about **21% taller** and had about **17% higher leaf product** than the case of 5% transmission.
- Kittas et al. (2004) found that UV reduction **increased the plant height**, the total **dry matter** production and the **leaf area** for tomatoes, without affecting bumblebees.
- Paul et al. (2005) confirmed that UV protection **increases the growth** of 5 species of herbs (including lettuce and peppermint).

- Kittas C, Papaioannou C, Obeid D, Katsoulas N, Tchamitchian M. Effect of two UV-absorbing greenhouse-covering films on growth and yield of an eggplant soil-less crop. *Scientia Horticulturae* 2006;110:30–7
- Kittas C, Papaioannou C, Obeid D, Katsoulas N, Tchamitchian M. Effect of two new UV-absorbing greenhouse-covering films on growth and yield of a tomato soil-less crop, *International Symposium of the eCIGR in Newtrends in Farmbuildings*, May 2–6, 2004, Evora, Portugal.
- Paul ND, Jacobson RJ, Taylor A, Wargent JJ, Moore JP. The use of wavelength selective plastic cladding materials in horticulture: understanding of crop and fungal responses through the assessment of biological spectral weighting functions. *Photochemistry and Photobiology* 2005;81:1052–60.

ADVANTAGES OF EXOLON SHEETS



UV protection: improvements in protection against insects and fungi

- Without UV, insects reduce the activity (movement and feeding) → **protection** against insect-borne viruses and general pathogens **without using pesticides**.
- Bumblebees for pollination are limited affected by the absence of UV because they adapt their visual system, however specific tests for specific applications are recommended when these insects are used to see the real effect on the activity (literature still debating).
- Sporulation is inhibited by reducing UV radiation → **fungi control**.

- Antignus Y. Manipulation of wavelength-dependent behaviour of insects: an IPM tool to impede insects and restrict epidemics of insect-borne viruses. *Virus Research* 2000;71:213–20.
- Dyer AG, Chittka L. Bumblebee search time without ultraviolet light. *The Journal of Experimental Biology* 2004;207:1683–8.
- Lammatau Chr., Chemisana D., solar radiation manipulations and their role in greenhouse claddings, 2012

CASE STUDY: POLYCARBONATE VS GLASS

Growth of cucumber and tomato

- PC transmits more light in PAR
- PC protects from UV

Covering material	Thickness (mm)	Transmittance (%)		
		UV	PAR	NIR
Polycarbonate	3.0	2.7	85.6	87.7
Glass	4.0	75.8	83.8	72.0

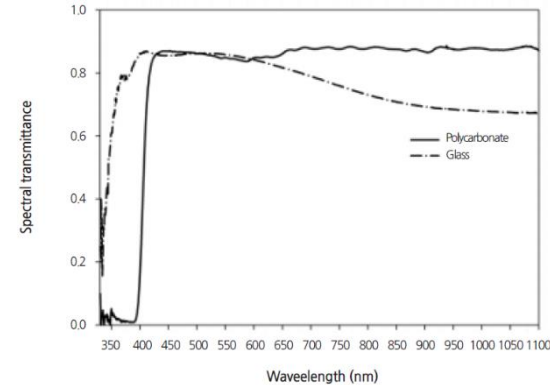

- Cucumber plants grown under polycarbonate were taller, produced a larger total leaf area, and had more fresh biomass than those grown under glass.
- The percentage of damaged and unsaleable tomatoes is lower for plants grown under polycarbonate.

POLYCARBONATE IN GREENHOUSES



- Types: multiwall
- Thickness: 4mm – 16mm

Advantages

- Longer life than film
- Unbreakable → ideal also for extreme wear
- Good fire reaction
- Easy to work and bend
- Light and good mechanical properties → lighter and cheaper structures
- Extreme thermal insulation → energy saving and control on the environment
- UV protection (safer environment for people and various effects on growth)

Disadvantages

- Requires proper UV protection
- Lower light transmittance, but compensate by diffusion, insulation and curved roof
- Thermal expansion
- Possible moisture or dirt in chambers

BOOST THE PERFORMANCES OF POLYCARBONATE



Yellowing?

- Exolon has a standard warranty of 10 years and custom available (e.g. 20 years)
- UV protection improves growth
- UV protection is a boost for the Integrated Pest Management

BOOST THE PERFORMANCES OF POLYCARBONATE



Light transmission

- Despite light transmission in full spectrum is lower, if we focus on PAR (photosynthetically active radiation), between 400 and 700nm, solid polycarbonate has good performances

Covering material	Thickness (mm)	Transmittance (%)		
		UV	PAR	NIR
Polycarbonate	3.0	2.7	85.6	87.7
Glass	4.0	75.8	83.8	72.0

- Cold bending allow optimized shapes

- Multiwall have lower light transmission to increase the thermal insulation, but it diffuses more light

BOOST THE PERFORMANCES OF POLYCARBONATE

Optimal shapes can improve the light

Cakir et al. (2015) studied the total solar radiation gain in a year for 5 greenhouses shapes

For each shape they calculated the optimum dimensions (L/W)
And the optimum orientation vs the cardinal points

For each optimal dimension and orientation, they calculated the
Total solar radiation for each geometry

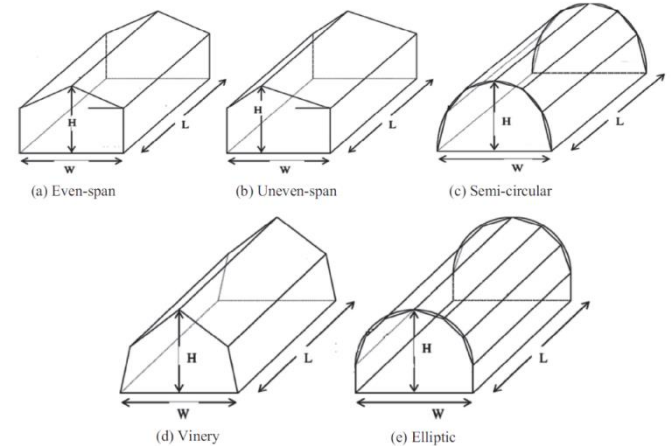

BOOST THE PERFORMANCES OF POLYCARBONATE

Optimal shapes can improve the light

Cakir et al. (2015) studied the total solar radiation gain in a year for 5 greenhouses shapes

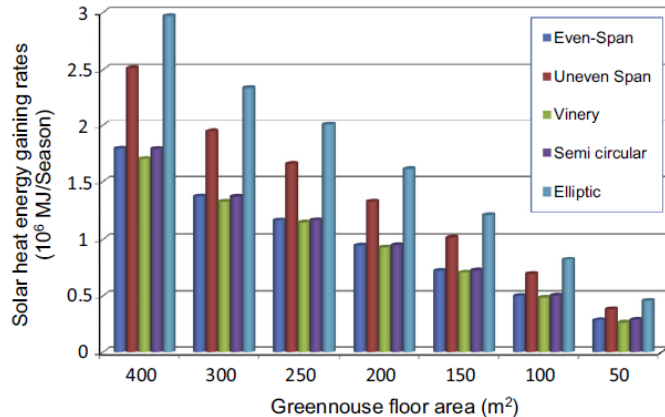

Elliptic curved shapes gives **18% more** solar heat uneven span (which si however very dependent on orientation) and **66% more** than even span.

PC si easy to work and the cold bending **allow**

BOOST THE PERFORMANCES OF POLYCARBONATE

Diffusive light can improve the growth

- Plants use diffuse light more efficiently because the photosynthetically saturation is avoided.
- Diffuse light penetrates deeper in the canopy because it has a lower extinction coefficient than direct light
- Avoids direct shadows of leaves
- Reduces the use of shading devices to avoid damage from direct light which reduce the yield

Direct



Diffuse



Cumulative crop photosynthesis can increase by 7%

BOOST THE PERFORMANCES OF POLYCARBONATE

Product	Thickness (mm)	Pitch (mm)	Area weight (kg/m ²)	Light transmittance for clear (%)	Light transmittance for opal(%)
Exolon Multi UV 2/4-8	4	8	0,8	82	80
Exolon Multi UV 2/6-8	6	8	1,3	82	80
Exolon Multi UV 2/8-10,5	8	10,5	1,5	81	78
Exolon Multi UV 2/10-10,5	10	10,5	1,7	80	70
Exolon Multi UV 2/16-30	16	30	3,6	77	57
Exolon Multi UV 2/4-8 UL	4	8	0,65	82	80
Exolon Multi UV 2/6-8 UL	6	8	1,05	82	80
Exolon Multi UV 2/8-8 UL	8	8	1,2	81	78
Exolon Multi UV 2/10-8 UL	10	8	1,3	80	70

More diffusion is obtained with a very limited reduction in light transmission

BOOST THE PERFORMANCES OF POLYCARBONATE



Exolon's technologies to improve PC sheets quality

- Continuous inline measurement system allows:
 - better tolerances;
 - better quality control (sheet by sheet);
 - better frames design to minimize the greenhouse capital costs

- Automatic taping system allows:
 - high quality tapes and taping
 - minimize the risk of dirt inside the chambers

CONTENTS

- Greenhouse basics
- Used materials – advantages of polycarbonate
- Exolon solutions for greenhouses
- Special features
 - » Light diffusion
 - » IR reflection
 - » NO Drop
 - » Esthetic

EXOLON TECH FOR INFRA RED REDUCTION

Side effects of IR

- IR is less absorbed by the plants → it is absorbed by construction elements → increase in temperature.
- If the T is too high, there might be a reduction in growth.
- The common solutions to avoid heat build up are:
 - shading: but strong reduction in light
 - aeration: but you loose the CO₂ self fertilization

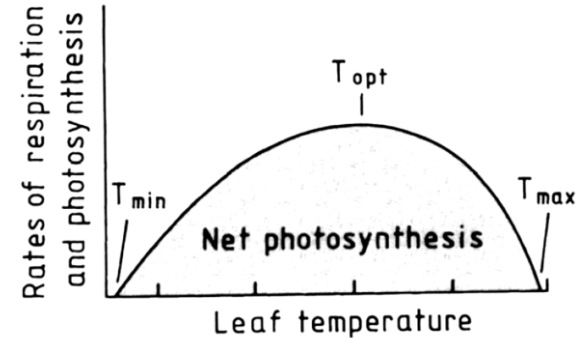

SUNLIGHT AND SOLAR ENERGY

Sun generates light and solar energy.

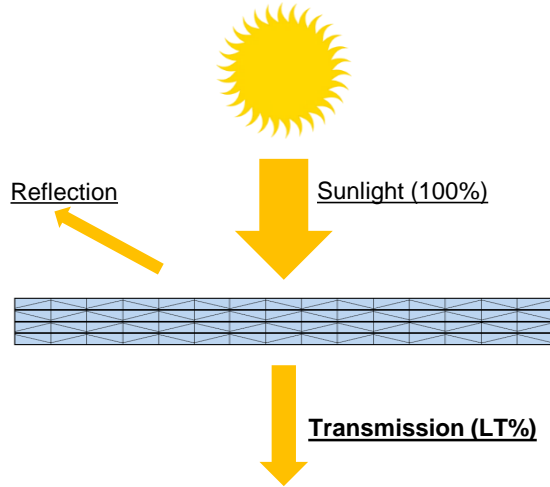

Light Transmission = % of light transmitted through the sheet

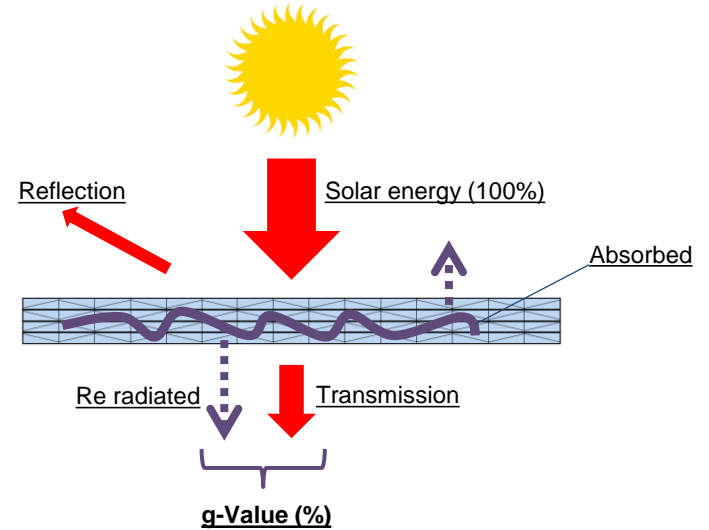

g-Value = % of solar energy that passes through the sheet (re radiated + transmitted)

SUNLIGHT AND SOLAR ENERGY

Different sheets technologies can interact in different ways with the two.

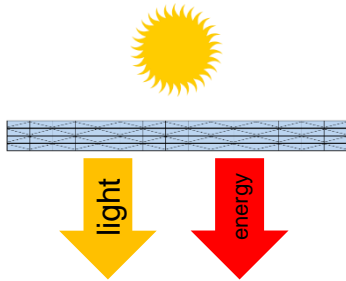

Clear sheet: high light and energy transmission

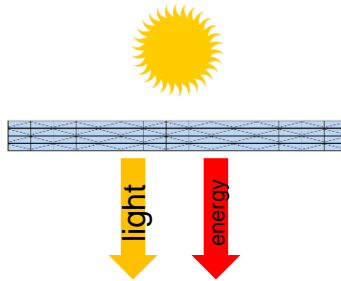

Reflective sheet: low light and energy transmission

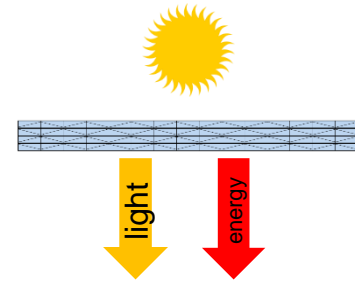

Selective sheet: optimal light and energy transmission

REDUCE INFRA RED WITH IQ-RELAX



- Opal sheet with built-in intelligent system that automatically adjust to ambient conditions.
- High selectivity: more light and less heat than standard opal sheets.
- Pleasant temperatures and better energy management

REDUCE INFRA RED WITH CLIMATE CONTROL



- Clear sheet with a special component able to absorb the IR avoiding its accumulation inside
- Very high selectivity, being still transparent (not opal) and further reducing the heat re radiated
- High control of heat build up and better energy management

BENEFITS OF IQ-RELAX AND CLIMATE CONTROL

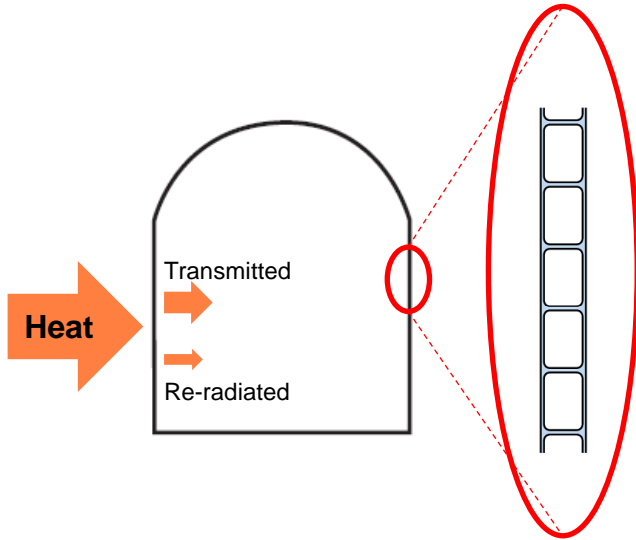

$$Q_{\text{sheet}} = A_{\text{sheet}} \cdot [U_g \cdot (T_e - T_i) + \text{SHGF}_{\text{max}} \cdot \text{SF}]$$

Q_{sheet} : heat exchanged through the sheet [W]

A_{sheet} : area of the sheet [m^2]

U_g : overall heat transfer coefficient of the sheet [$\text{W}/\text{m}^2\text{K}$]

T_e : external temperature (dry bulb) [$^{\circ}\text{C}$]

T_i : internal temperature (dry bulb) [$^{\circ}\text{C}$]

SHGF_{max} : solar heat gain [W/m^2]

SF: shading coefficient [adim.]

BENEFITS OF IQ-RELAX AND CLIMATE CONTROL

$$Q_{\text{sheet}} = A_{\text{sheet}} \cdot [Ug \cdot (T_e - T_i) + \text{SHGF}_{\text{max}} \cdot \text{SF}]$$

Q_{sheet} : heat exchanged through the sheet [W]

A_{sheet} : area of the sheet [m²]

Ug: overall heat transfer coefficient of the sheet [W/m²K]

T_e : external temperature (dry bulb) [°C]

T_i : internal temperature (dry bulb) [°C]

SHGF_{max} : solar heat gain [W/m²]

SF: shading coefficient [adim.]

→ 1 m²

→ 3,3 W/m²K (for 2WN/8)

→ 43°C dry bulb, (24°C wet bulb)

→ 25°C dry bulb, (50% RH)

→ 300 W/m²

→ **improvement of 10-20% thanks to IQ-Relax-CC Clear**

$Q_{\text{saved}} = 15-30 \text{ W each m}^2 \text{ of sheet}$

BENEFITS OF IQ-RELAX AND CLIMATE CONTROL



The application of IQ-Relax or CC Clear is increasing the light in and reducing the heat build up

The reduction in heat can be estimated in 15-30 W for each m², this means a saving in 1 year of:

- 11-22 kg of diesel
- Or 14-28 Nm³ of natural gas
- Or 0,06-0,12 MWh of electrical energy



For each 1m² there is a yearly save in energy with a reduction in CO₂ emission of 35-70 kg

EXOLON NO-DROP



Side effects of water condensation

- Negative impact on growth because droplets reduce light transmission
- Increases the risk of diseases with a consequent increase in pesticides uses
- Risk of reduced quality due to water droplets falling

EXOLON NO-DROP



- Prevents droplets formation dispersing the condensation to a continuous film
- The film has limited effect on light transmission because it flows off along the sheet in a controlled manner
- The sheet dries quickly and without mark
- Better control on plant growth and quality in high humid environment or in cold regions

CONTENTS

- Greenhouse basics
- Used materials – advantages of polycarbonate
- Exolon solutions for greenhouses
- Special features
 - » Light diffusion
 - » IR reflection
 - » NO Drop
 - » Esthetic

EXOLON MULTI 2W16-30



Product	Thickness (mm)	Pitch (mm)	Area weight (kg/m ²)	Light transmittance for clear (%)	Ug vertical (W/m ² K)
Exolon Multi UV 2/4-8	4	8	0,8	82	4,0
Exolon Multi UV 2/6-8	6	8	1,3	82	3,5
Exolon Multi UV 2/8-10,5	8	10,5	1,5	81	3,3
Exolon Multi UV 2/10-10,5	10	10,5	1,7	80	3,0
Exolon Multi UV 2/16-30	16	30	2,85-3,6	77	2,8

High thickness for thermal insulation

Very high pitch to maximize the light transmission

Vitalization to have a glass like brightness

2W16-30: ESTHETIC

- Special multiwall 2W in 16mm and pitch 30mm
- Maximize light transmission
- Maximized load bearing
- 20 years warranty
- Proprietary surface treatment to have a glass-like effect



2W16-30: ESTHETIC



NO VITALIZATION



VITALIZATION

CONCLUSIONS



- Exolon provides a **complete portfolio** of Exolon sheets solutions to optimize the greenhouse.
- Exolon PC can be used to design **optimal shaped** greenhouses.
- Exolon PC is easy to work, cold bend and with good fire reaction.
- The high PAR transparency combined to **UV protection improves the growth.**
- UV protection **protects the workers** and help in **Integrated Pest Management.**
- Thermal insulation improves the growth and **reduce the resources consumptions.**
- **Special types** available: diffusive, anti IR, No Drop.
- **2W16-30** a unique product that combines **esthetics and performances.**

EXTRUSION EXCELLENCE



- We are leader in polycarbonate mono and multi sheets
 - We develop cutting edge technologies
 - We believe in the strength of partnerships
- We are committed to grow together



THANK YOU FOR THE ATTENTION