

VSSC6SL LD 12VDC 0.5A

Weidmüller Interface GmbH & Co. KG

Klingenbergstraße 26

D-32758 Detmold

Germany

www.weidmueller.com

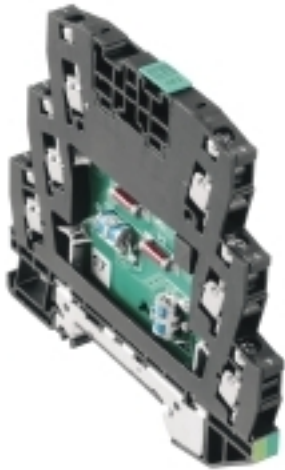

Overvoltage coupling along the conductor path may disturb or destroy sensitive signal inputs. It is important to provide protection in the immediate vicinity of I&C devices. Weidmüller's broad product range for the I&C sector offers products in a 2-piece, pluggable design and modular terminals for tension clamp or screw connection. These products are suitable for both binary and analogue signals. Weidmüller also offers other designs with integrated components such as gas discharge tubes or varistors. VARITECTOR stands for flexible and variable surge protection by Weidmüller, tested according to product standard IEC61643-21. The VARITECTOR series can be used in applications according to IEC 61643-22 / VDE 0845-3 for classes C1, C2, C3 and D1. The VARITECTOR SPC, SSC and MCZ OVP product families optimally combine electrical and mechanical properties. Size and easy handling play an important role. This surge protection is suited for confined spaces in industrial and process automation as well as in building automation applications.

General ordering data

Version	Surge protection for instrumentation and control, Surge protection for measurement and control, $U_p(L/N-PE) \leq 100 \text{ V}$
Order No.	1064340000
Type	VSSC6SL LD 12VDC 0.5A
GTIN (EAN)	4032248829705
Qty.	10 pc(s).

VSSC6SL LD 12VDC 0.5A
Weidmüller Interface GmbH & Co. KG

Klingenbergstraße 26

D-32758 Detmold

Germany

www.weidmueller.com

Technical data
Dimensions and weights

Depth	81 mm	Depth (inches)	3.189 inch
Height	88.5 mm	Height (inches)	3.484 inch
Width	6.2 mm	Width (inches)	0.244 inch
Net weight	40.57 g		

Temperatures

Storage temperature	-40 °C...80 °C	Operating temperature	-40 °C...70
Humidity	5...96 %		

Probability of failure

SIL in compliance with IEC 61508	3	MTTF	2,114 a
SFF	96.67 %	λges	54
PFH in 1*10 ⁻⁹ per hour	1.8		

Rated data UL

Certificate No. (UL)	E311081	UL certificate	UL Zertifikat
----------------------	---------	----------------	---------------

CSA protection data

Gas group C	IIB	Gas group D	IIA
Gas groups A, B	IIC	Input current, max. I _i	500 mA
Input voltage, max. U _i	15 V	Internal capacity, max. C _i	2 nF
Internal inductance, max. L _i	0 μH		

General data

Colour	black	Design	Terminal
Isolating function	No	Optical function display	Yes
Protection degree	IP20	Rail	TS 35
Segment	Measurement - Monitoring - Setting	UL 94 flammability rating	V-0
Version	Surge protection for mea- surement and control		

Insulation coordination acc. to EN 50178

Pollution severity	2	Surge voltage category	III
--------------------	---	------------------------	-----

VSSC6SL LD 12VDC 0.5A**Weidmüller Interface GmbH & Co. KG**

Klingenbergstraße 26

D-32758 Detmold

Germany

www.weidmueller.com

Technical data**Rated data IEC / EN**

Discharge current I_{max} (8/20 μ s) wire-PE	10 kA	Discharge current I_n (8/20 μ s) wire-PE	2.5 kA
Discharge current, max. (8/20 μ s)	20 kA	Fuse	0.5 A
Insertion loss	732.08 kHz	Leakage current at U_n	3.2 mA
Lightning test current I_{imp} (10/350 μ s)	1 kA	Lightning test current, I_{imp} (10/350 μ s)	1 kA
Max. continuous voltage, U_c (DC)	15 V	Wire-PE	1 kA
Overload - failure mode	Modus 2	Number of poles	1
Pulse-reset capacity	≤ 20 ms	Protection level U_p (typ.)	≤ 100 V
Rated voltage (DC)	12 V	Rated current I_N	500 mA
Signal transmission properties (-3 dB)	750 KHz	Requirements category acc. to IEC 61643-21	C2, C3, D1
Surge current-carrying capacity C2	2.5 kA 8/20 μ s	Standards	IEC 61643-21
Surge current-carrying capacity D1	1 kA 10/350 μ s	Surge current-carrying capacity C3	10 A 10/1000 μ s
Volume resistance	1.8 Ω 10 %	Voltage type	DC

Further details of approvals

GOST certificate GOST-Zertifikat

Connection data

Stripping length	10 mm	Type of connection	Screw connection
Tightening torque, min.	0.5 Nm	Tightening torque, max.	0.8 Nm
Clamping range, min.	0.5 mm ²	Clamping range, max.	4 mm ²
Wire cross-section, solid, min.	0.5 mm ²	Wire cross-section, solid, max.	6 mm ²
Conductor cross-section, flexible, AEH (DIN 46228-1), min.	0.5 mm ²	Conductor cross-section, flexible, AEH (DIN 46228-1), max.	4 mm ²
Connection cross-section, stranded, min.	0.5 mm ²	Connection cross-section, stranded, max.	4 mm ²

Ratings IECEx/ATEX/cUL

cUL certificate cUL Certificate

Classifications

ETIM 6.0	EC000943	ETIM 7.0	EC000943
ETIM 8.0	EC000943	ETIM 9.0	EC000943
ECLASS 9.0	27-13-08-07	ECLASS 9.1	27-13-08-07
ECLASS 10.0	27-13-08-07	ECLASS 11.0	27-13-08-07
ECLASS 12.0	27-17-90-90	ECLASS 13.0	27-17-90-90
ECLASS 14.0	27-17-90-90		

VSSC6SL LD 12VDC 0.5A

Weidmüller Interface GmbH & Co. KG

Klingenbergstraße 26

D-32758 Detmold

Germany

www.weidmueller.com

Technical data

Tender specification sheets

Long specification	Surge protection in a one piece, 6.2 mm wide DIN rail module for two binary, potential-free signal circuits with 12 V DC. Signal indication via a green LED. When the terminal is fitted, a simultaneous electrically conducting contact is made between the mounting rail (earth) and the reference potential (ground) of the protection circuit in the terminal. Optical identification of the terminal based on the type of protected switching and the voltage level. The terminal can be labelled or marked.	Short specification
		Surge protection in a one piece, 6.2 mm wide DIN rail module for two binary, potential-free signal circuits. Signal indication via a green LED. Version: 12V DC

Environmental Product Compliance

RoHS Compliance Status	Compliant with exemption
RoHS Exemption (if applicable/known)	7a, 7c1
REACH SVHC	Lead 7439-92-1
SCIP	71e97bb7-979f-4330-94c0-20c629bb05e3

Important note

Product information	Mode 2: State where the voltage-limiting part of the SPD was short-circuited due to a very low impedance within the SPD. The line is inoperable, but the measuring equipment is still protected by means of a short-circuit.
---------------------	--

Approvals

Approvals



ROHS	Conform
UL File Number Search	UL Website
Certificate No. (UL)	E311081

Downloads

Approval/Certificate/Document of Conformity	SIL Paper EU Konformitätserklärung / EU Declaration of Conformity
Engineering Data	CAD data – STEP
User Documentation	Beipackzettel / Instruction sheet
Catalogues	Catalogues in PDF-format
Brochures	

Data sheet

VSSC6SL LD 12VDC 0.5A

Weidmüller Interface GmbH & Co. KG
Klingenbergstraße 26
D-32758 Detmold
Germany

www.weidmueller.com

Drawings

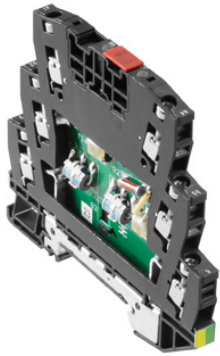

Similar to illustration

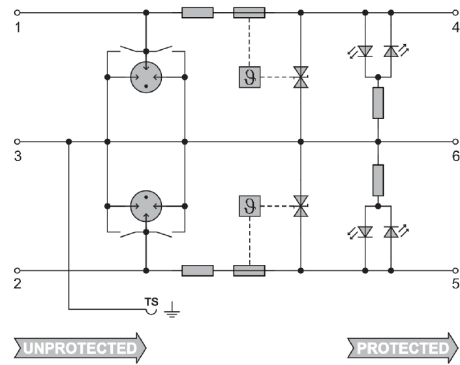

Circuit diagram

